

# PARTS LIST

## V7002D/UTC L5001M/UTC SERIES

Industrial Sewing Machines

V 7002D/UTC

V 7003D/UTC

L 5001M/UTC

V 7002-IS

W 8003-IS

DMM2202F

DMM2203F

Industrial Sewing Machines

**Kansai Special**

From the library of: Superior Sewing Machine & Supply LLC



## Contents

<b>1. Thread tension adjuster(UTC) or organization parts</b> (糸ユルメ装置及びサブクラス構成部品)	
V7002D/UTC, V7003D/UTC, L5001M/UTC .....	1
<b>2. Under trimming knife (下糸切り機構)</b>	
V7002D/UTC, V7003D/UTC, L5001M/UTC .....	3
<b>3. Thread wiper solenoid (ワイパー機構) .....</b>	5
<b>4. Air control diagram foot lifter (押え揚げエア機構) .....</b>	7
<b>5. Feed rocker and Looper (送り台及びルーパー機構) L5001M/UTC .....</b>	9
<b>6. Attachment components (アタッチメント機構) V7002-1S, W8003-1S .....</b>	13
<b>7. Attachment, Cover components</b> (アタッチメント、カバー関係) V7002-1S, W8003-1S .....	15
<b>8. Thread eyelet components (糸調子機構) V7002-1S, W8003-1S .....</b>	17
<b>9. Looper (ルーパー台機構) V7002-1S, W8003-1S .....</b>	19
<b>10. Thread eyelet and cover components</b> (糸道機構、及びカバー関係) DMM .....	21
<b>11. Spreader mechanism (飾り機構) DMM2202, 2203 .....</b>	23
<b>12. Gauge (ゲージ関係) .....</b>	25



# 1. Thread tension adjuster (UTC) or organization parts

(糸ユルメ装置及びサブクラス構成部品)

V7002D/UTC, V7003D/UTC, L5001M/UTC

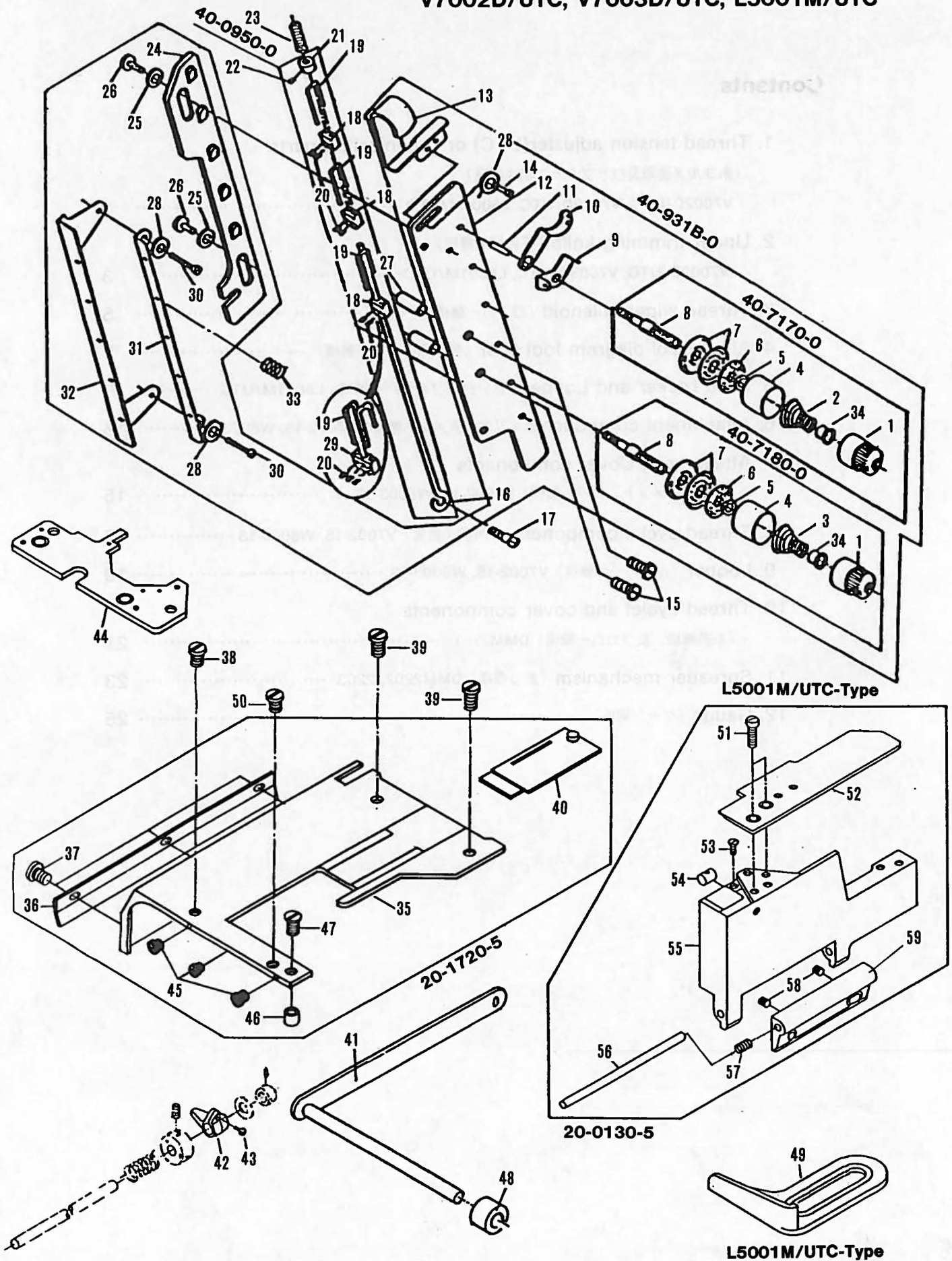



No.	Part No.	Part Name	品 名	Q, ty
1	41-1010-0	Adjusting nut	チャンボン皿小ケース	3
2	41-7010-0	Spring (strong)	チャンボン調子バネ (強)	2
3	41-7020-0	Spring (weak)	チャンボン調子バネ (弱)	1
4	41-1070-0	Disc cover	大ケース	3
5	33-8020-0	Tension disc washer	チャンボン座金	3
6	23-3240-0	Felt	フェルト	3
7	41-1110-0	Disc	チャンボン皿	6
8	41-1750-0	Tension post	上糸調子棒	3
9	41-1150-0	Thread eyelet	糸道上	3
10	41-1170-0	Thread eyelet	糸道下	3
11	06-9440-0	Thread release pin	上糸ユルメピン	3
12	41-7290-0	Tension post holder	チャンボン元台	1
13	06-9480-0	Thread release post guide	糸ユルメ棒ガイド 上	1
14	84-3610-0	Screw	ネ ジ	2
15	84-7650-0	Screw	ネ ジ	2
16	41-7260-0	Thread release post B	糸ユルメ棒 B	1
17	84-7820-0	Screw	ネ ジ	1
18	06-0670-0	Hook holder	糸ユルメスライド	3
19	06-0710-0	Hook	糸ユルメ用フック	3
20	84-3140-0	Screw	ネ ジ	6
21	75-9410-0	Thread release cushion collar	糸ユルメクッションカラー	1
22	84-3140-0	Screw	ネ ジ	1
23	79-9140-0	Thread release cushion spring	糸ユルメクッションバネ	1
24	41-7300-0	Tension post support	チャンボン調節板	1
25	75-9420-0	Tension post collar	チャンボンカラー	2
26	84-5590-0	Tension post slide screw	ネ ジ	2
27	75-9430-0	Tension post collar	チャンボンカラー	2
28	75-4550-0	Washer	ワッシャ	4
29	06-0170-0	Tension release slide	糸緩めスライド	1
30	84-3740-0	Screw	ネ ジ	2
31	41-7280-0	Thread release guide thread eyelet (right)	糸ユルメ案内糸道 (右)	1
32	41-7270-0	Thread release guide thread eyelet (left)	糸ユルメ案内糸道 (左)	1
33	79-1640-0	Spring	バネ	1
34	41-1050-0	Tension disc ratchet	チャンボン皿ラチェット	3
35	21-7250-0	Upper cloth plate	上ベースカバー	1
36	21-4430-0	Supporting cover	上ベース補助カバー	1
37	84-5740-0	Screw	ネ ジ	3
38	84-8620-0	Screw	ネ ジ	1
39	84-8610-0	Screw	ネ ジ	2
40	21-5210-0	Slide plate	差板	1
41	77-8890-0	Control lever	押え揚げレバー	1
42	77-8040-0	Stopper	ストッパー	1
43	84-8140-0	Screw	ネ ジ	1
44	14-0760-2	Needle plate support	針板土台	1
45	25-8010-0	Cashion	防振ゴム	3
46	71-1190-0	Ruller plate stopper	定規台ストッパー	1
47	84-6640-0	Screw	ネ ジ	1
48	75-8880-0	Foot lifter connecting collar	押え揚げスペースカラー	1
49	26-5520-0	Guide	ガイド定規	1
50	84-8620-0	Screw	ネ ジ	1
51	84-5720-0	Screw	ネ ジ	2
52	21-1940-0	Ruller plate	定規板	1
53	84-4620-0	Screw	ネ ジ	1
54	71-4010-0	Setting pin for ruller holder spring	定規台裏バネピン	1
55	21-1080-0	Ruller holder	定規台	1
56	71-3080-0	Hinge pin	ヒンジピン	1
57	79-2330-0	Spring	取付巻バネ	2
58	84-3140-0	Screw	ネ ジ	2
59	25-1080-0	Hinge	定規台取付ヒンジ	1



## 2. Under trimming knife (下糸切り機構)

V7002D/UTC, V7003D/UTC, L5001M/UTC

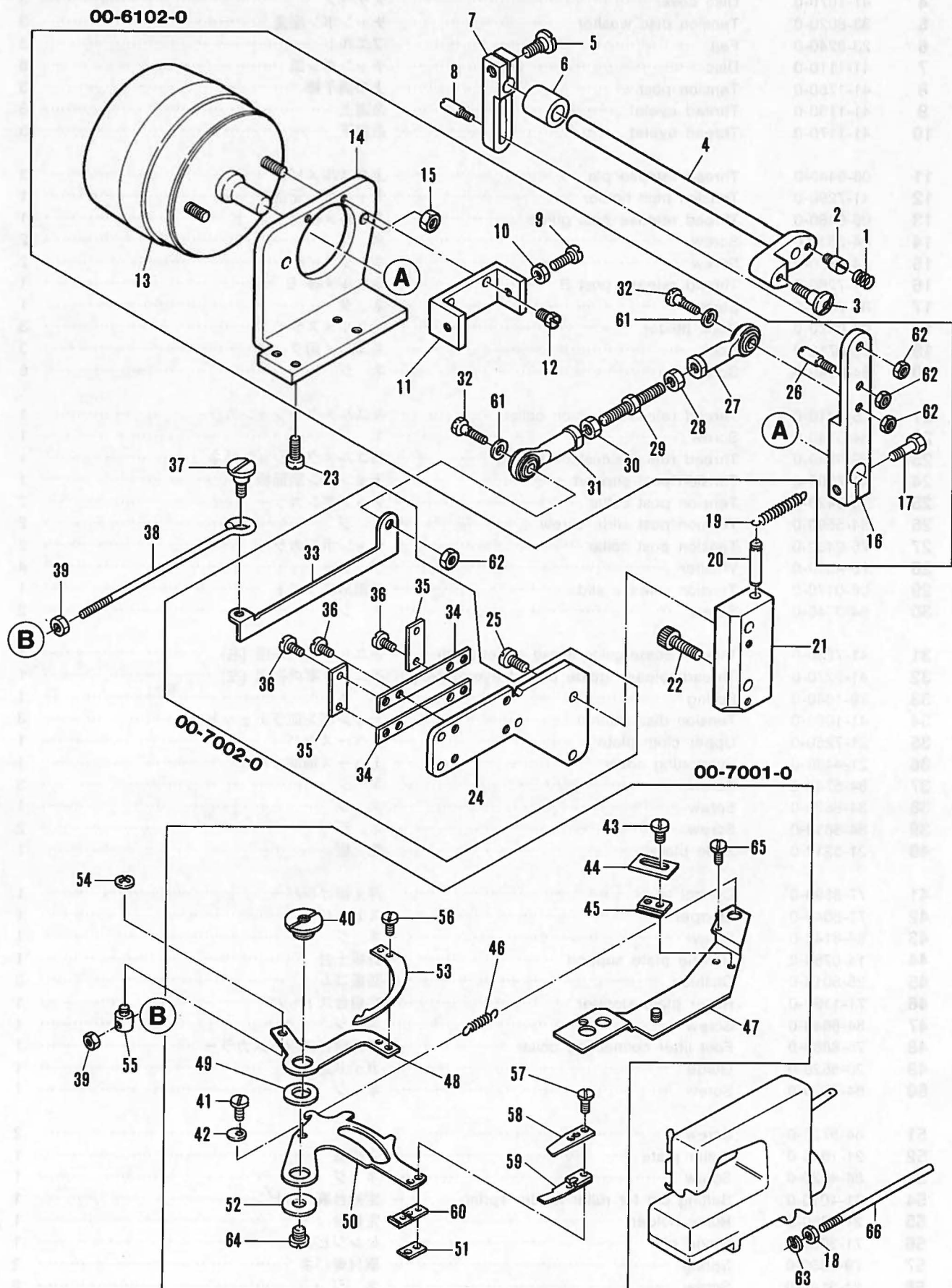



No.	Part No.	Part Name	品 名	Q, ty
1	79-1640-0	Spring	バネ	1
2	84-5610-0	Screw	ネジ	1
3	84-7820-0	Screw	ネジ	1
4	06-7120-0	Thread release cam	糸ユルメカム	1
5	84-7920-0	Screw	ネジ	1
6	06-7140-0	Space collar	糸ユルメカムスペースカラー	1
7	06-7130-0	Thread release driving lever	糸ユルメメス駆動レバー	1
8	84-7060-0	Screw	ネジ	1
9	84-7640-0	Screw	ネジ	2
10	86-4110-0	Nut	ナット	2
11	06-7150-0	Stopper	ストッパー金具	1
12	84-8160-0	Screw	ネジ	2
13	06-8480-0	Solenoid	メスソレノイド	1
14	06-7110-0	Solenoid bracket	メスソレノイドブラケット	1
15	88-1660-0	Nut	ナット	2
16	06-7040-0	Solenoid lever	メスソレノイドレバー	1
17	84-8120-0	Screw	ネジ	1
18	88-1660-0	Nut	ナット	1
19	79-1290-0	Solenoid spring	メスソレノイド引張バネ	1
20	01-7320-0	Spring pin	ゴムガイドスプリングピン	1
21	06-7060-0	Knife drive base	メススライド金具ブラケット	1
22	87-1710-0	Screw	ネジ	2
23	84-5680-0	Screw	ネジ	4
24	06-7100-0	Knife drive connecting base	メススライド連結土台	1
25	84-5660-0	Screw	ネジ	2
26	84-1040-0	Screw	ネジ	1
27	04-3480-0	Thread cutter drive rod end (right)	ロットエンド(右)	1
28	88-1570-0	Nut	ナット 右	1
29	06-7050-0	Connecting rod	ソレノイド連結棒	1
30	88-1580-0	Nut	ナット 左	1
31	04-3490-0	Thread cutter drive rod end (left)	ロットエンド(左)	1
32	84-6330-0	Screw	ネジ	2
33	06-7010-0	Thread cutter drive plate	メススライド金具	1
34	06-7020-0	Thread cutter drive guide	メススライドガイド	2
35	06-7030-0	Locking plate	スライド止め板	2
36	84-1610-0	Screw	ネジ	6
37	06-7090-0	Screw	メスソレノイド連結ネジ	1
38	06-7070-0	Thread cutter drive connecting rod	メス駆動連結バー	1
39	88-1370-0	Nut	ナット	2
40	06-7690-0	Nut	可動メス支点ナット	1
41	84-1170-0	Screw	ネジ	1
42	06-7700-0	Thread cutter adjusting plate	メス位置アジャスト金具	1
43	84-1170-0	Screw	ネジ	2
44	06-7710-0	Fixed knife adjusting plate	固定メスアジャスト金具	1
45	06-7720-0	Fixed knife stopper	固定メスストッパー	1
46	79-7030-0	Spring	メスクッションバネ	1
47	06-7750-0	Thread cutter base	メス土台プレート	1
48	06-7640-0	Movable knife carrier	可動メスレバー	1
49	75-1780-0	Washer	ワッシャ	1
50	06-7630-0	Fixed knife carrier	固定メス土台	1
51	06-7680-0	Fixed knife holder	バネ調節座金	1
52	75-1790-0	Washer	固定メスワッシャ	1
53	06-7620-0	Movable knife	可動メス	1
54	93-2010-0	E-ring	Eリング	1
55	06-7080-0	Carrier connector	可動メス駆動ピン	1
56	84-1170-0	Screw	ネジ	2
57	84-7720-0	Screw	ネジ	3
58	06-7610-0	Fixed knife	固定メス	1
59	06-7670-0	Clamp spring	メス裏バネ	1
60	06-7660-0	Adjusting spacer	メス裏バネ調節板	1
61	75-4530-0	Washer	ワッシャ	2
62	86-3120-0	Nut	ナット	3
63	75-5520-0	Washer	ワッシャ	1
64	84-1150-0	Screw	ネジ	1
65	84-1610-0	Screw	ネジ	2
66	06-2260-0	Positioner bar	ポジションナバー	1



### 3. Thread wiper solenoid (ワイパー機構)

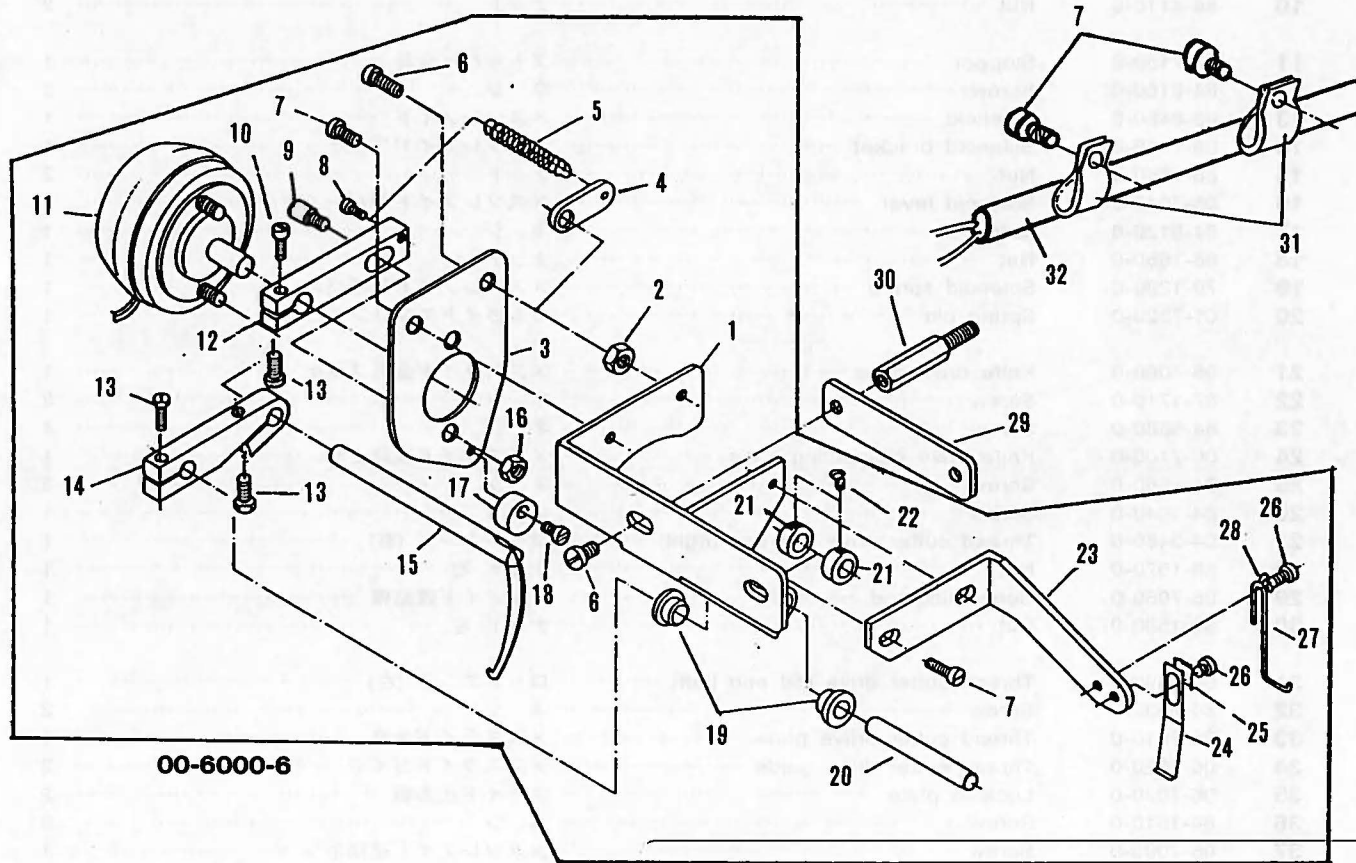

No.	Part No.	Part Name	品 名	Q, ty
1	06-6880-0	Wiper bracket	糸払いブラケット	1
2	86-3110-0	Nut	ナット	1
3	06-6790-0	Solenoid bracket	ソレノイドブラケット	1
4	06-6840-0	Wiper spring stopper bracket	糸払いバネ止め金具	1
5	79-7030-0	Spring	メスクッションバネ	1
6	84-5660-0	Screw	ネジ	3
7	84-5640-0	Screw	ネジ	7
8	84-1610-0	Screw	ネジ	1
9	84-7060-0	Screw	ネジ	1
10	84-3140-0	Screw	ネジ	1
11	06-6770-0	Wiper solenoid	上糸払いソレノイド	1
12	06-6800-0	Solenoid connecting lever	ソレノイド連結レバー	1
13	84-4130-0	Screw	ネジ	3
14	06-6740-0	Wiper lever	糸払いレバー	1
15	06-6750-0	Wiper	糸払いワイパー	1
16	88-1460-0	Nut	ナット	2
17	06-6830-0	Wiper adjusting bracket	糸払いアジャスト金具	1
18	87-1400-0	Screw	ネジ	1
19	06-6820-0	Bushing	ブッシュ	2
20	06-6810-0	Wiper drive shaft	ワイパー駆動軸	1
21	75-0970-0	Collar	ゴム案内装置ストップカラー	2
22	84-3610-0	Screw	ネジ	2
23	06-6710-0	Thread catching bracket	糸掴みブラケット	1
24	06-6760-0	Thread catching spring	糸掴み板バネ	1
25	06-6330-0	Plate spring washer	板バネ用角ワッシャ	1
26	84-3640-0	Screw	ネジ	2
27	06-6780-0	Upper thread catching spring	上糸払い用糸掴みバネ	1
28	75-4680-0	Tubing fixing washer	配管取付けワッシャ	1
29	06-6730-0	Wiper bracket space liner	糸払いブラケットスペースライナー	1
30	06-7510-0	Screw	ネジ	2
31	06-9350-0	Wiper cord guard	パイプサポーター	4
32	06-3010-0	Wiper cord	配線コード	1

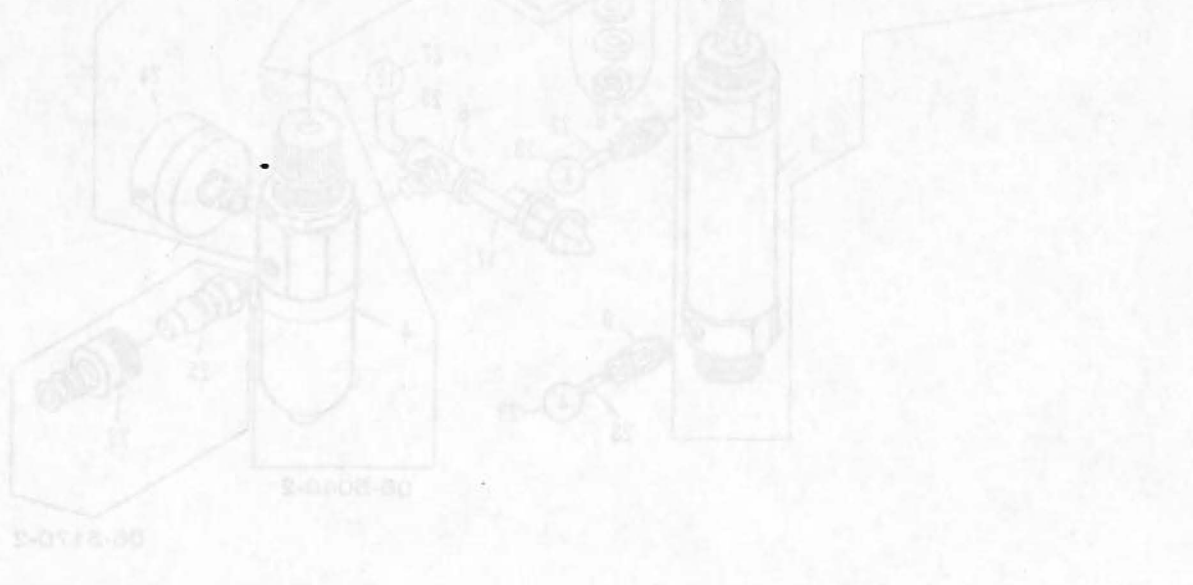



#### 4. Air control diagram foot lifter (押え揚げエア機構) UTC

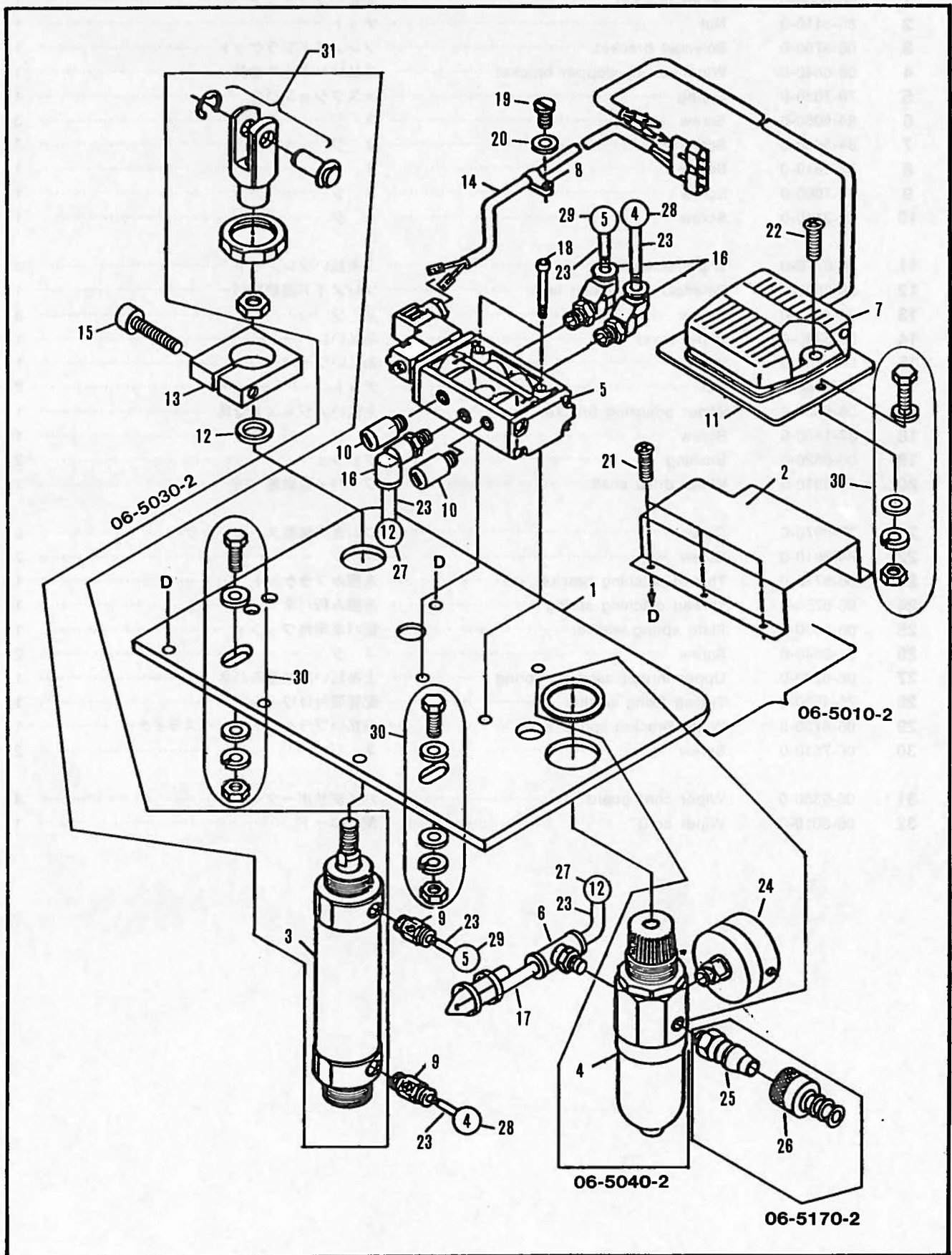

06-7240-2



No.	Part No.	Part Name	品 名	Q, ty
1	06-5010-0	Base plate	ベースプレート	1
2	06-5500-0	Cover (small)	カバー小	1
3	06-5030-0	Air cylinder (80mm)	シリンダー (Yナックル付) 80mm	1
4	06-5040-0	Regulator	レギュレーター本体	1
5	06-5060-0	Solenoid valve	電磁弁	1
6	06-9780-0	T-type joint	ジョイントGT4-6	1
7	06-5350-0	Foot switch with wiring harness	フットスイッチ (配線コード付)	1set
8	06-5120-0	Wire mount	線止めサドル	1
9	06-2960-0	Joint	ジョイントGS4-6	2
10	06-5150-0	Silencer	サイレンサー	2
11	06-5520-0	Foot pedal base	フットペダルベース (ネジ付)	1set
12	23-1900-0	O-ring P-10	O-リング P-10	1
13	06-3150-0	Cylinder stopper	シリンダーストッパー	1
14	06-3060-0	Wiring harness	配線コード (モレックスハウジング付)	1set
15	87-1880-0	Screw	ネジ	1
16	06-5190-0	L-type joint	ジョイント GL4-6	3
17	06-5230-0	Plug	栓	1set
18	87-1160-0	Screw	ネジ	2
19	87-2090-0	Screw	ネジ	1
20	06-3170-0	Washer	ワッシャー	1
21	06-3160-0	Screw	ネジ	5
22	06-3180-0	Screw	ネジ	2
23	09-9400-0	Air tube	ジュンロンチューブ	1
24	06-5210-0	Regulator gauge	レギュレーター用メーター	1
25	06-5170-0	Coupler	カブラオス	1
26	06-5160-0	Socket pipe	カブラメス	1
27	06-5720-0	Mark sheet No12	マークシートNo12	4
28	06-5640-0	Mark sheet No4	マークシートNo4	4
29	06-5650-0	Mark sheet No5	マークシートNo5	4
30	80-7520-0	Mounting set	ボルトセット	4set
31	06-5510-1	Y-Knuckle	シリンダー用Yナックル	1set

# 5. Feed rocker and Looper (送り台及びルーパー機構) L5001M/UTC

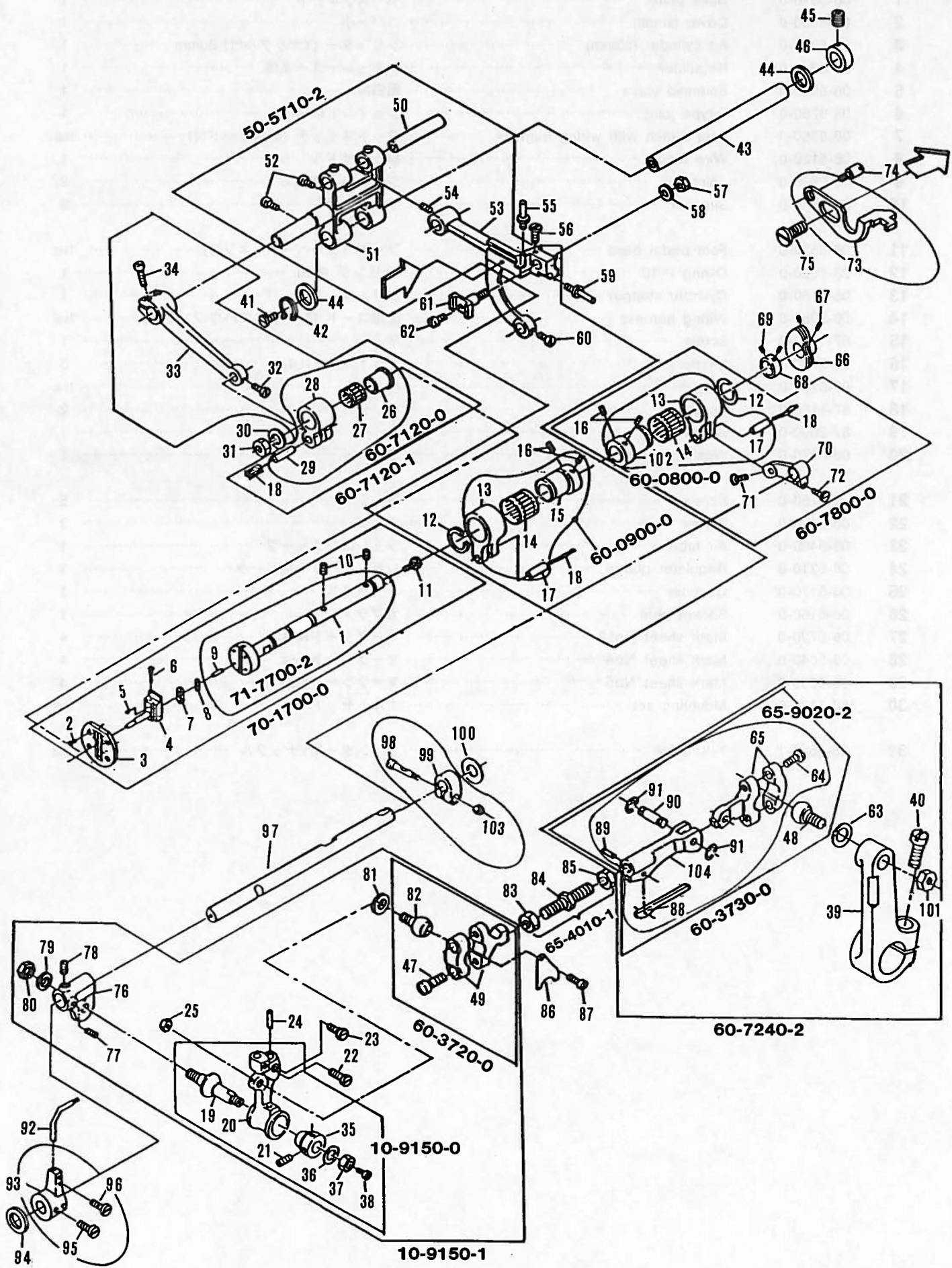



No.	Part No.	Part Name	品 名	Q, ty
1	71-7530-0	Main shaft 5C	前下シャフト 5C	1
2	84-6610-0	Screw	ネ ジ	4
3	51-0310-0	Head plate	メインシャフトヘッドプレート	1
4	51-0130-0	Feed crank adjusting post	送り調節芯棒	1
5	85-6240-0	Screw	ネ ジ	1
6	84-3830-0	Screw	ネ ジ	1
7	23-1970-0	O-ring	Oリング	1
8	51-0360-0	Oil guide	オイルガード	1
9	23-3930-0	Felt	フェルト	1
10	23-3410-0	Felt	フェルト	1
11	84-5760-0	Screw	ネ ジ	1
12	93-4060-0	Snap ring	スナップリング	2
13	63-2320-U	Feed eccentric link	エキセンダルマ B	2
14	91-4060-0	Bearing	ベアリング	2
15	61-3220-0	Feed eccentric 0.9	針返しエキセン玉B	1
16	84-5210-0	Screw	ネ ジ	4
17	71-4310-0	Connecting link pin	ダルマピン	2
18	23-3410-0	Felt	フェルト	3
19	71-9010-0	Looper rocker tapered	ルーバー台テーパーピン	1
20	19-3150-0	Looper holder set	ルーバー台	1
21	84-5210-0	Screw	ネ ジ	2
22	84-6160-0	Screw	ネ ジ	1
23	84-1610-0	Screw	ネ ジ	1
24	71-2160-0	Pin	ピン	1
25	86-4130-0	Nut	ナット	1
26	75-2430-0	Feed crank link roller	送りダルマローラC	1
27	91-2710-0	Bearing	ベアリングA	1
28	63-3530-2	Feed rocker link A	送りダルマ	1
29	71-4320-0	Feed rocker link pin	メガネピン	1
30	75-4530-0	Washer	ワッシャ	1
31	86-4120-0	Nut	ナット	1
32	84-3660-0	Screw	ネ ジ	1
33	67-3110-1	Feed rocker arm	送り連結レバーA	1
34	84-6120-0	Screw	ネ ジ	2
35	81-4010-1	Tapered pin bushing	テーパーピン押ブッシュ	1
36	75-4520-0	Washer	ワッシャ	1
37	86-5010-0	Nut	ナット	1
38	84-3610-0	Screw	ネ ジ	1
39	67-2420-1	Looper driving lever C	ルーバー振り元レバーC	1
40	85-2100-0	Screw	ネ ジ	1
41	84-5760-0	Screw	ネ ジ	1
42	93-2610-0	Snap ring	φ10C形止め輪	1
43	71-6420-0	Feed rocker shaft small	送り元台シャフト	1
44	75-3720-0	Washer	ワッシャ	2
45	84-8160-0	Screw	ネ ジ	1
46	75-1320-1	Collar	10.34φシャフトカラー	1
47	84-5670-0	Screw	ネ ジ	2
48	61-8230-U	Connecting ball	ルーバー連結ロット玉 左	1
49	63-8120-1	Connecting rod	連結ロット 左	1
50	71-5310-0	Feed rocker arm shaft	後送り歯取付台シャフト	1



# Feed rocker and Loper (送り台及びルーパー機構) L5001M/UTC

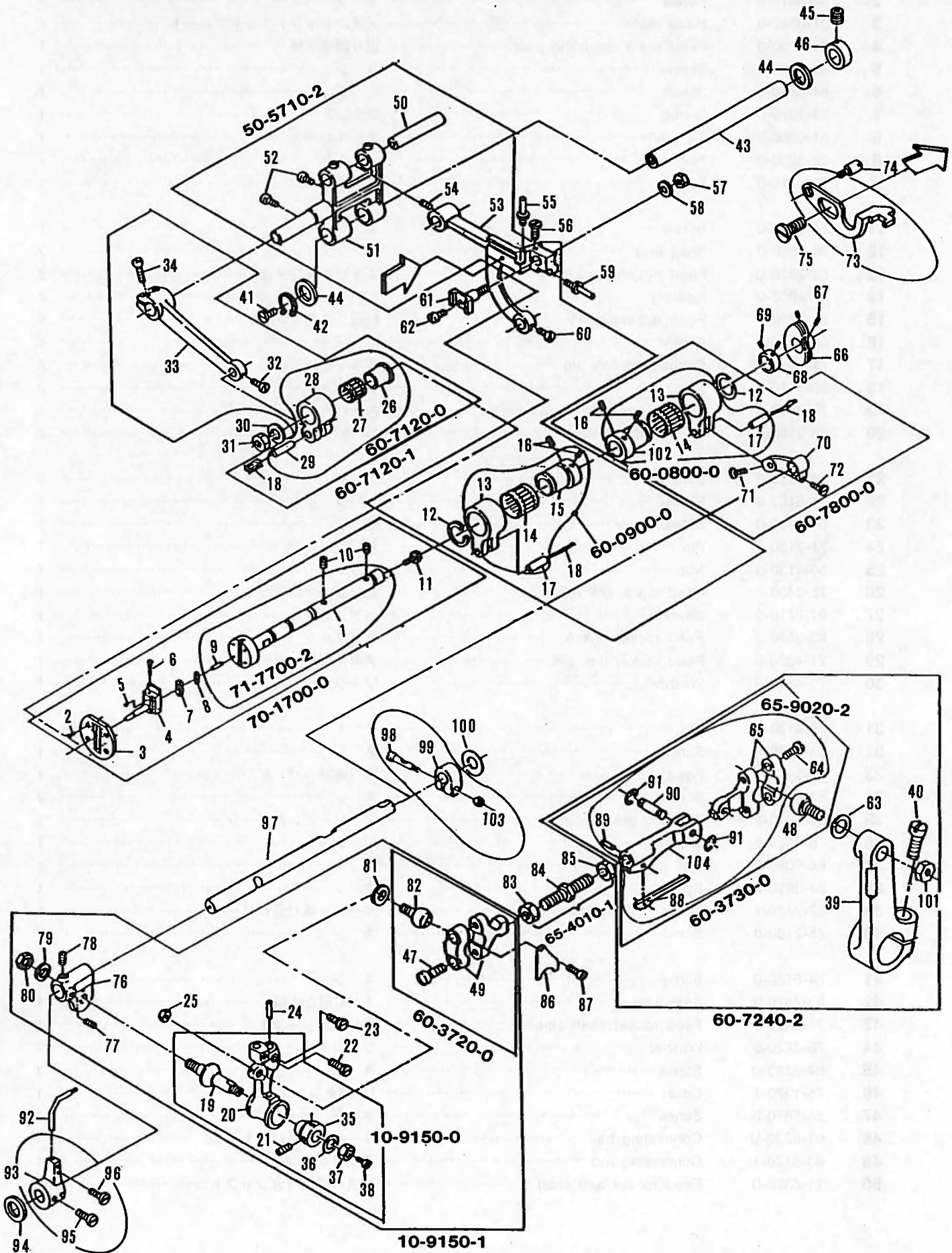



No.	Part No.	Part Name	品 名	Q, ty
51	55-0410-0	Single feed rocker arm	1枚送り元台	1
52	84-5210-0	Screw	ネジ	2
53	55-1760-0	Feed rocker	送り土台	1
54	84-7120-0	Screw	ネジ	1
55	84-1770-0	Screw	ネジ	1
56	84-4630-0	Screw	ネジ	1
57	86-5010-0	Nut	ナット	1
58	75-3810-0	Washer	ワッシャ	1
59	84-1760-0	Screw	ネジ	1
60	84-3660-0	Screw	ネジ	1
61	55-0510-0	Feed dog holder	送り歯取付台	1
62	84-5880-0	Screw	ネジ	1
63	75-4010-0	Washer	ワッシャ	1
64	84-5720-0	Screw	ネジ	2
65	63-8210-U	Connecting rod	ルーバー折り曲げロッド	1
66	49-1410-1	Looper thread double disc take up	ハマグリ	1
67	84-7110-0	Screw	ネジ	2
68	75-1140-1	Collar	ハマグリカラー	1
69	84-5110-0	Screw	ネジ	2
70	67-1320-1	Looper avoid lever	針返しダルマレバー	1
71	84-3660-1	Screw	ネジ	1
72	84-6120-0	Screw	ネジ	1
73	18-5010-0	Needle guard	針受け	1
74	84-1130-0	Screw	ネジ	1
75	84-3680-0	Screw	ネジ	1
76	19-3030-0	Looper rocker	ルーバー元台	1
77	84-7670-0	Screw	ネジ	1
78	84-7660-0	Screw	ネジ	1
79	75-3810-0	Washer	ワッシャ	1
80	86-5020-0	Nut	ナット	1
81	75-4530-0	Washer	ワッシャ	1
82	61-8230-U	Connecting ball	ルーバー振り元ロッド玉	1
83	86-4120-0	Nut	ナット	1
84	65-4010-1	Connecting bar	連結棒 (大)	1
85	86-4110-0	Nut	ナット	1
86	35-1990-0	Gaude fork	ルーバー台用オイル案内板	1
87	84-1610-0	Screw	ネジ	1
88	79-6010-0	Plate spring	折り曲げロッド用板バネ	1
89	71-2010-0	Pin	ノックピン	1
90	71-3220-0	Pin	折り曲げダルマピン	1
91	93-2010-0	Stop ring	ストップリング	2
92	18-7250-0	Front needle bar guide	前針ガイド	1
93	18-7220-0	Needle bar guide bracket A	針ガイドブラケットA	1
94	75-3720-0	Washer (small)	ワッシャ小	1
95	84-8160-0	Screw	ネジ	1
96	84-1620-0	Screw	ネジ	1
97	71-5610-0	Looper holder shaft B	ルーバー台シャフトB	1
98	71-4540-0	Pin	締めカラー止メピン	1
99	75-1390-1	Looper holder shaft collar B	ルーバー台シャフト締めカラーB	1
100	75-3720-0	Washer (small)	ワッシャ小	1
101	86-4110-0	Nut	ナット	1
102	61-3120-0	Feed eccentric 0.79	針返しエキセン玉 (0.79)	1
103	86-3140-0	Nut	ナット	1
104	65-9020-0	Looper driving connecting link	ルーバー折り曲げダルマ金具	1



# 6. Attachment componets (アタッチメント機構) V7002-IS, W8003-IS

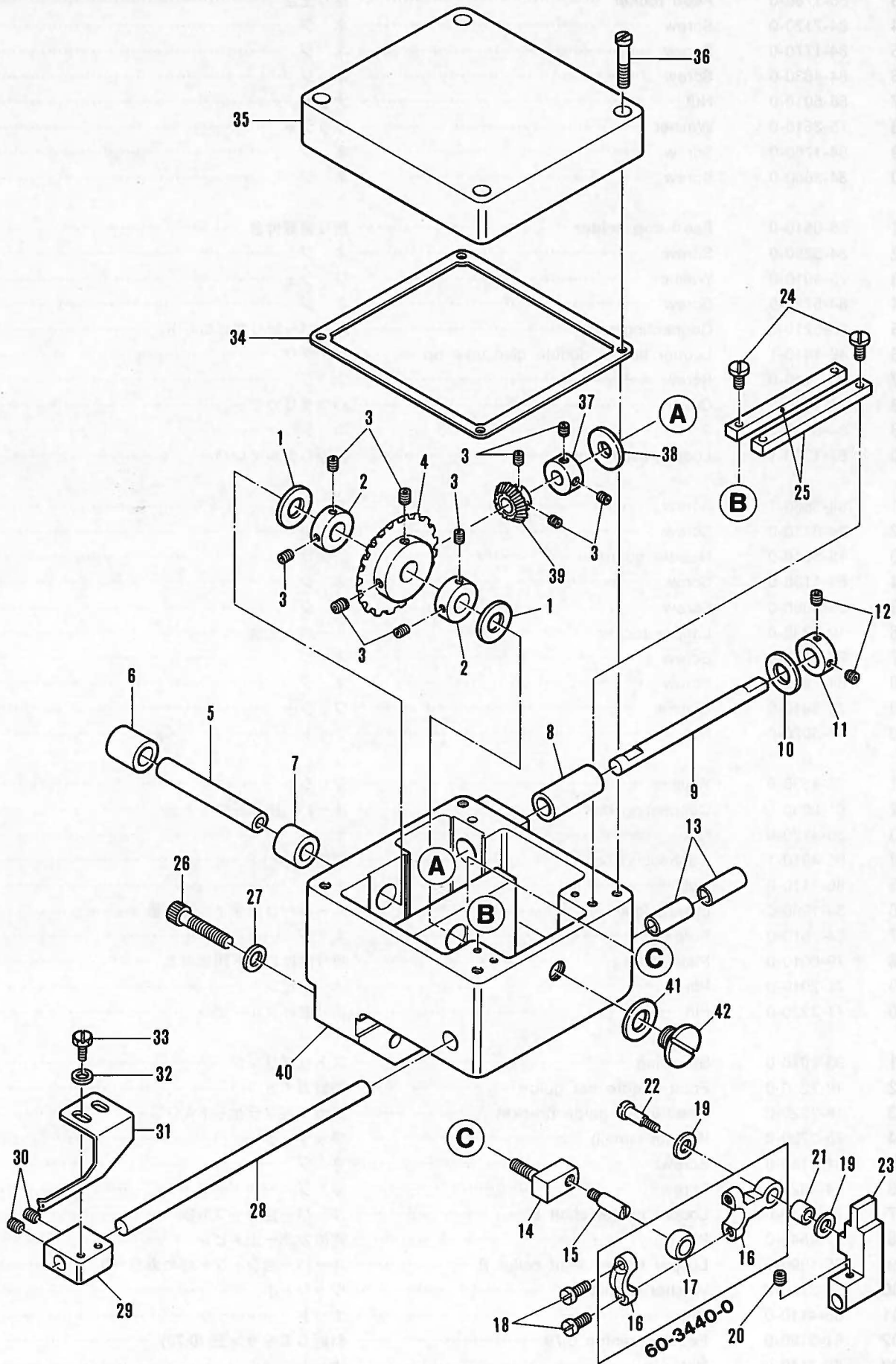

No.	Part No.	Part Name	品 名	Q, ty
1	75-3720-0	Washer	ワッシャ	2
2	75-0020-0	Collar	φ10カラー	2
3	84-5210-0	Screw	ネジ	10
4	04-7100-0	Large bevel gear	カサハグルマ(大)	1
5	71-5590-0	Shaft	φ10シャフト	1
6	81-6030-0	Bushing	φ10ブッシュ(B)	1
7	81-6040-0	Bushing	φ10ブッシュ(C)	1
8	81-6010-0	Bushing	φ8ブッシュ	1
9	71-5160-0	Shaft	φ8シャフト	1
10	75-5010-0	Washer	ワッシャ	1
11	75-0010-0	Collar	φ8カラー	1
12	84-5210-0	Screw	ネジ	2
13	81-1710-0	Bushing for retainer holder	針棒ブッシュ	2
14	04-7050-0	Crank	クランク	1
15	84-7880-0	Screw	上メスブラケット連動ピン	1
16	63-8100-1	Puller connecting rod	連結メガネ	1
17	61-8410-U	Ball joint	タマ	1
18	84-5720-0	Screw	ネジ	2
19	75-4580-0	Washer	ワッシャ	2
20	84-7180-0	Screw	ネジ	1
21	75-2470-0	Roller	ローラー	1
22	84-5830-0	Screw	ネジ	1
23	04-7260-0	Slide shaft bracket	スライドシャフトブラケット	1
24	84-3630-0	Screw	ネジ	4
25	04-7060-0	Guide plate	案内板	2
26	85-6280-0	Screw	ボルト	2
27	75-5270-0	Washer	バネ座金	2
28	71-5000-0	Slide shaft	スライドシャフト	1
29	04-7080-0	Scallop plate bracket	スカラ爪ブラケット	1
30	84-5210-0	Screw	ネジ	2
31	04-7270-0	Nail	スカラ爪	1
32	75-4680-0	Washer	ワッシャ	2
33	84-4010-0	Screw	ネジ	2
34	23-7020-0	Gear box gasket	ギヤボックスパッキン	1
35	04-7020-0	Gear box lid	ギヤボックスフタ	1
36	84-5890-0	Screw	ネジ	4
37	75-0010-1	Collar	φ8カラー	1
38	75-5010-0	Washer	φ8ワッシャ	1
39	04-7110-0	Small bevel gear	カサハグルマ(小)	1
40	04-7010-0	Gear box	ギヤボックス	1
41	23-3040-0	Gasket	パッキン	1
42	87-3110-0	Screw	ネジ	1



**7. Attachment, Cover components (アタッチメント, カバー関係) V7002-IS, W8003-IS**

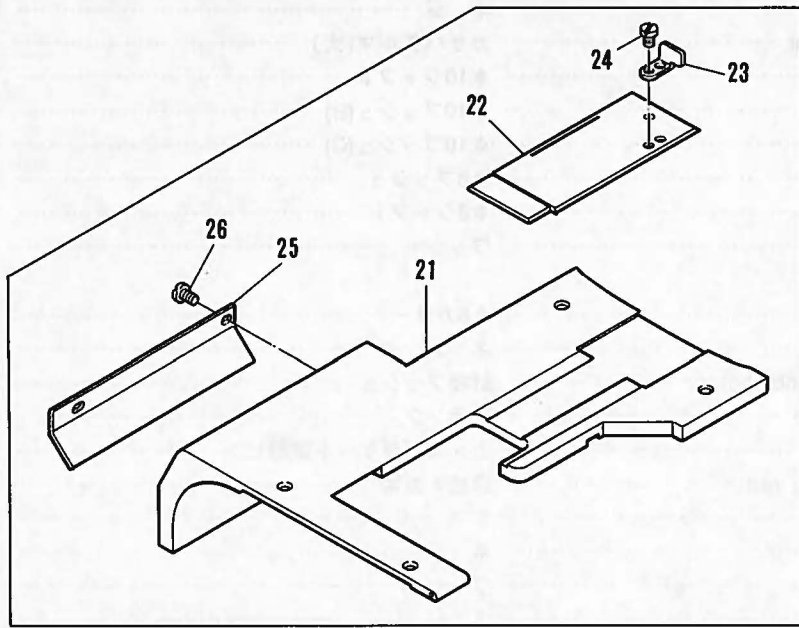

**20-1720-4**

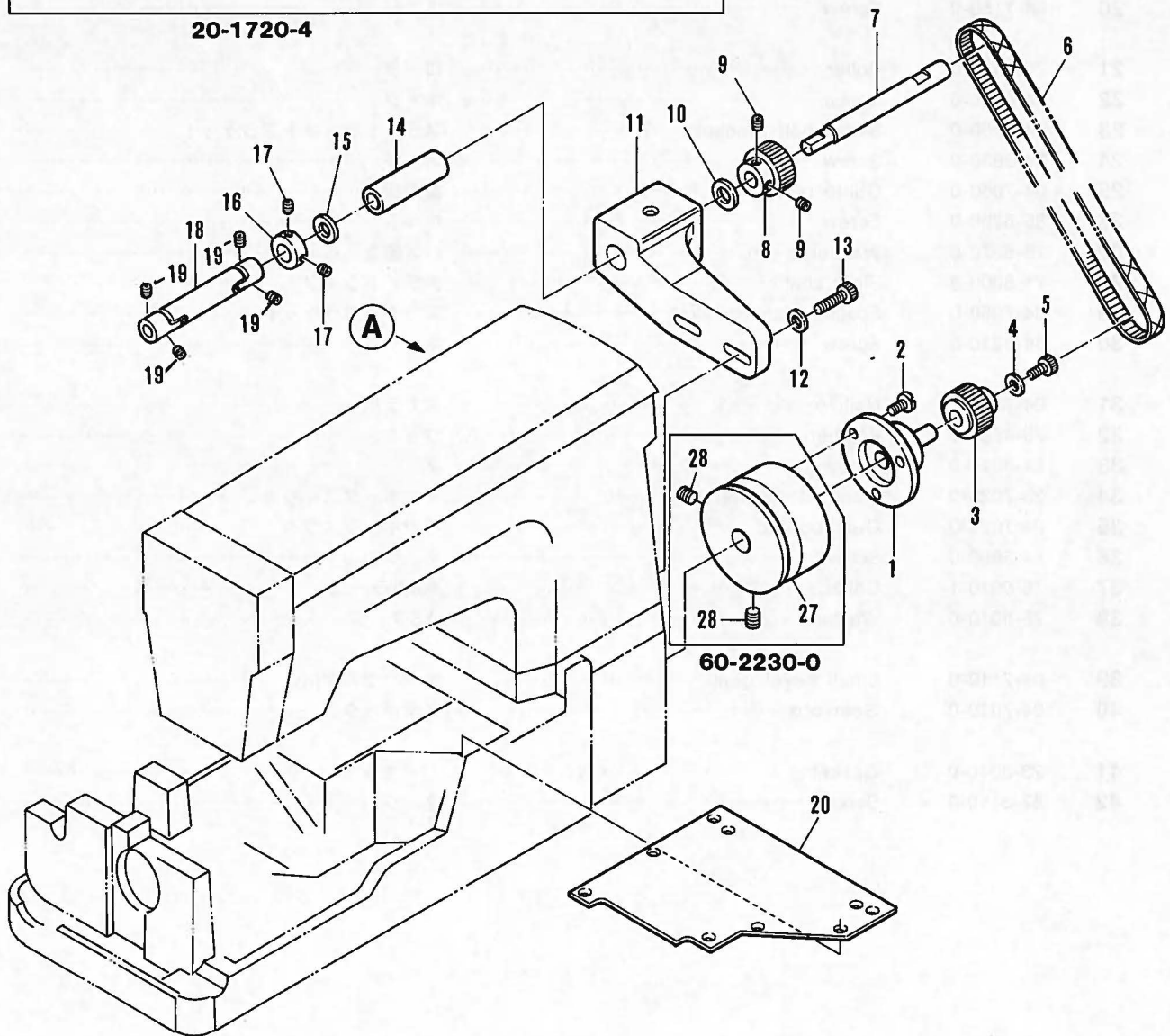
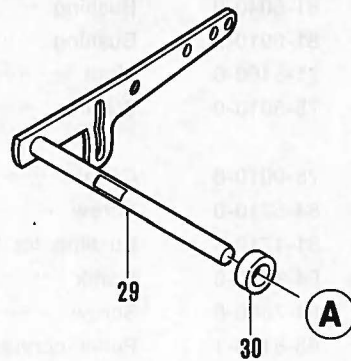

**60-2230-0**

No.	Part No.	Part Name	品名	Q, ty
1	04-7000-0	Pulley adapter	プーリーアダプター	1
2	87-1450-0	Screw	ネジ	3
3	04-7180-0	Timing pulley (small)	タイミングプーリー (小)	1
4	75-5510-0	Washer	ワッシャ	1
5	87-1710-0	Screw	ボルト	1
6	04-7160-0	Timing belt	タイミングベルト	1
7	71-5600-0	Timing pulley mount shaft	タイミングプーリー取付シャフト	1
8	04-7170-0	Timing pulley (large)	タイミングプーリー (大)	1
9	84-5210-0	Screw	ネジ	2
10	75-3720-0	Washer	ワッシャ	1
11	04-7030-0	Timing pulley bracket	タイミングプーリーブラケット	1
12	75-5270-0	Washer	バネ座金	2
13	87-1730-0	Screw	ネジ	2
14	81-6020-0	Bushing	φ10ブッシュ	1
15	75-3720-0	Washer	ワッシャ	1
16	75-0020-1	Collar	φ10カラー	1
17	84-5210-0	Screw	ネジ	2
18	04-7150-0	Universal joint	ユニバーサルジョイント	1
19	84-5210-0	Screw	ネジ	4
20	21-5060-0	Top oil cover	上油カバー	1
21	21-7240-1	Upper cloth plate	上ベースカバー	1
22	21-5350-0	Side plate	差板	1
23	21-5360-0	Access plate handle	差板ハンドル	1
24	84-1670-0	Screw	ネジ	2
25	21-4420-0	Sub cover	上ベース補助カバーB	1
26	84-5740-0	Screw	ネジ	2
27	69-2230-0	Pulley	プーリー	1
28	85-1140-0	Screw	ネジ	2
29	77-8130-0	Presser lifting lever	押工揚げレバー	1
30	75-8880-0	Collar	押工揚げカラー	1

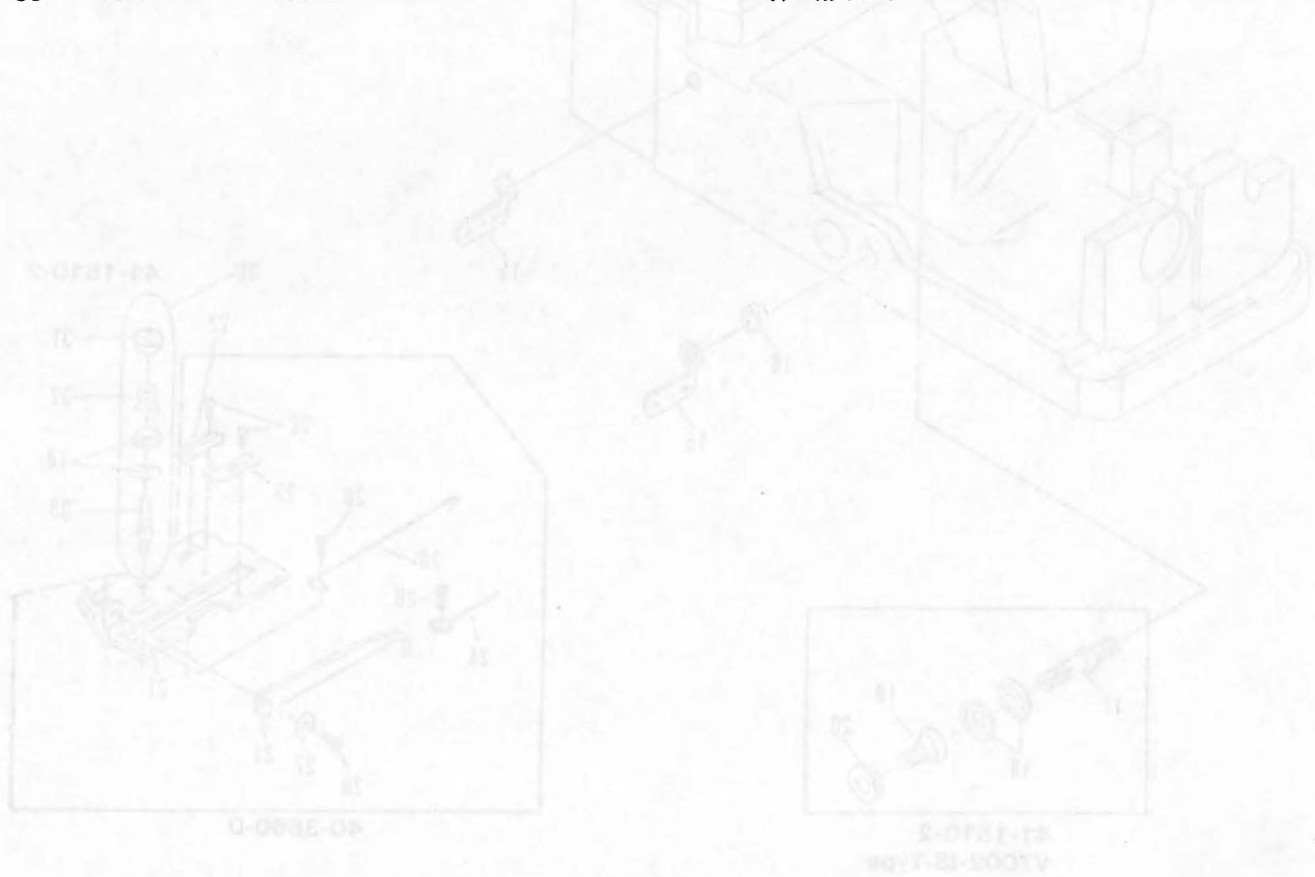



Thread eyelet components (糸調子機構) V7002-IS, W8003-IS

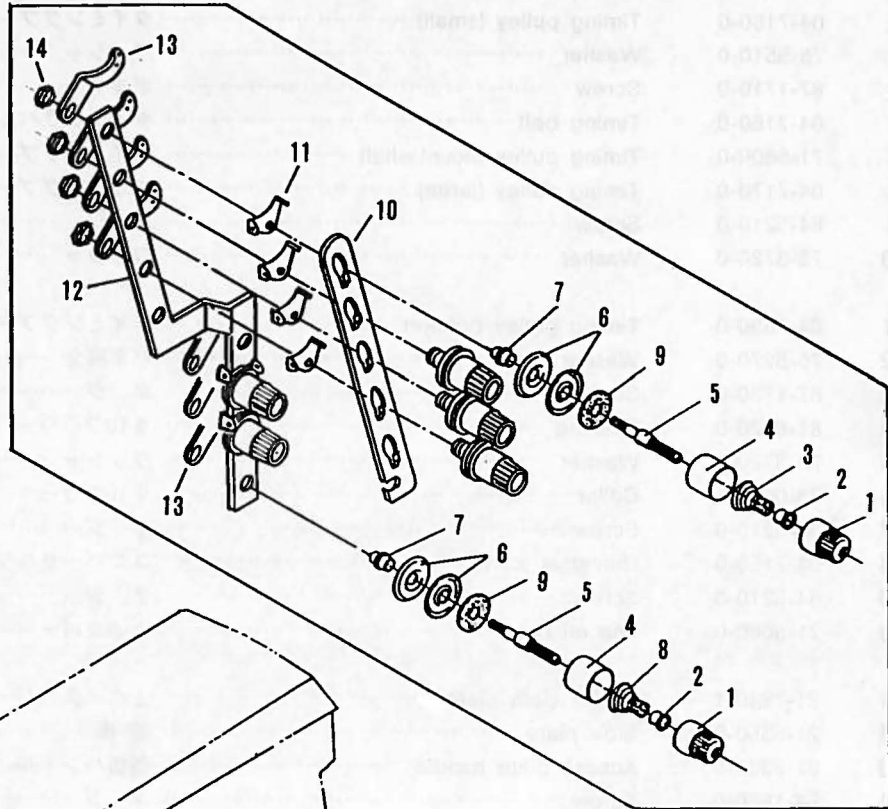

40-8430-0  
W8003-IS-Type

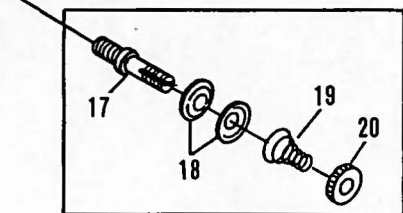
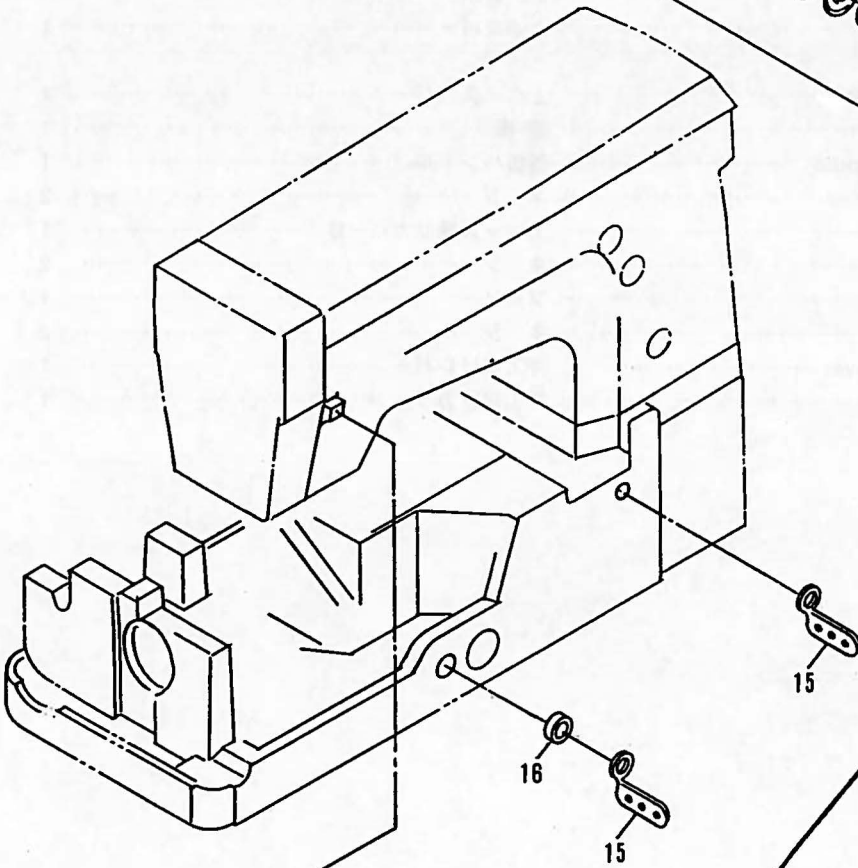

41-1510-2  
V7002-IS-Type

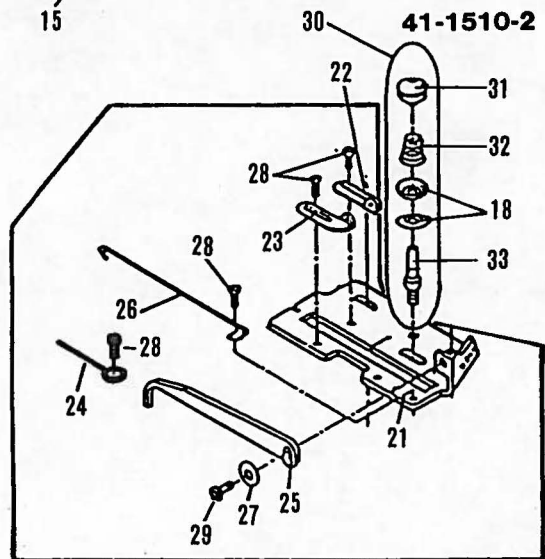

40-3860-0

No.	Part No.	Part Name	品 名	Q, ty
1	41-1010-0	Adjusting nut	チャンボン皿小ケース	7
2	41-1050-0	Adjusting ratchet	チャンボン皿ラチェット	7
3	41-7010-0	Spring strong	チャンボン調子バネ強	4
4	41-1070-0	Disc cover	チャンボン皿大ケース	7
5	41-1720-0	Tension post	調子棒中	7
6	41-1110-0	Disc	チャンボン皿	14
7	41-1310-0	Collar	調子棒カラーA	7
8	41-7020-0	Spring weak	チャンボン調子バネ弱	3
9	23-3240-0	Felt	取付けフェルト	7
10	41-236B-0	Tension post support	チャンボン皿調節板	1
11	41-1150-0	Thread eyelet	糸道上	7
12	41-1240-0	Tension post holder	チャンボン元板	1
13	41-1170-0	Thread eyelet	糸道下	7
14	86-4110-0	Nut	ナット	4
15	47-1660-0	Looper thread eyelet	下糸糸道W3	2
16	75-1570-1	Collar	カラー	1
17	41-1510-0	Looper thread guide tension stud	下糸チャンボン用調子棒	1
18	41-1520-0	Tension nipper	捌き用小チャンボン皿	4
19	41-1530-0	Spring	バネ	1
20	41-1540-0	Nut	ナット	1
21	43-3420-0	Cast-off support bracket	下糸捌き板	1
22	47-1280-0	Looper thread guide eyelet (right)	下糸捌き板案内糸道 (右)	1
23	47-1270-0	Looper thread guide eyelet (left)	下糸捌き板案内糸道 (左)	1
24	43-1050-0	Pin	下糸捌きピン	1
25	43-3440-0	Looper thread retainer	下糸捌き上	1
26	43-3380-0	Looper thread retainer	下糸捌き下ピン	1
27	75-4680-0	Washer	ワッシャ	1
28	84-1610-0	Screw	ネジ	4
29	84-3610-0	Screw	ネジ	1
30	41-1510-2	Needle thread tension post	小チャンボンセット	1
31	41-1540-0	Nut	ナット	1
32	41-1530-0	Spring	バネ	1
33	41-1510-0	Looper thread guide tension stud	下糸チャンボン用調子棒	1



# 9. Looper (ルーパー台機構) V7002-IS, W8003-IS

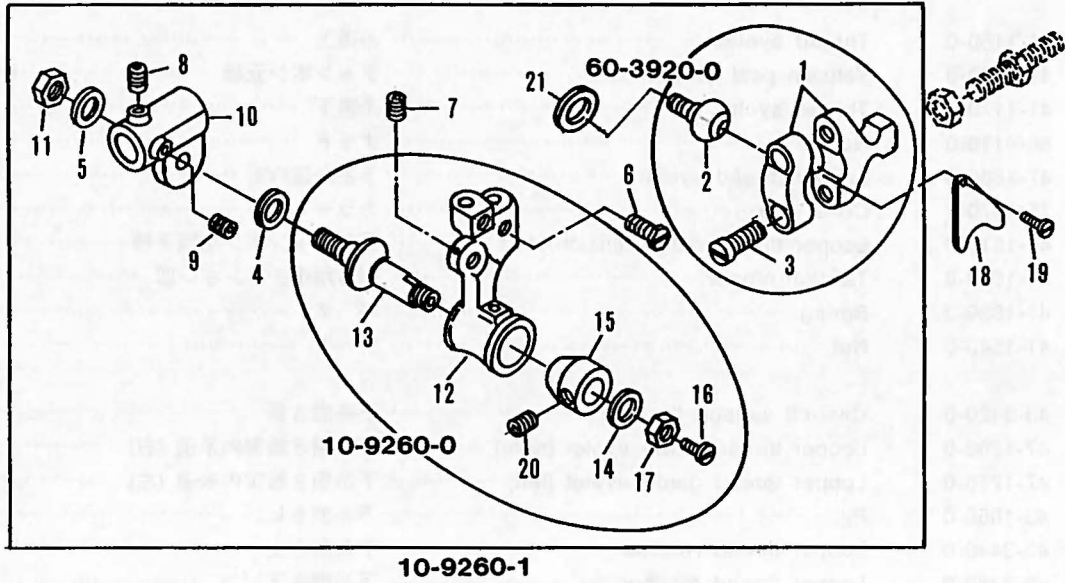

No.	Part No.	Part Name	品名	Q, ty
1	63-8120-1	Connecting rod (left) .....	連結ロッド (左) .....	1
2	61-5130-U	Connecting ball (left) .....	ルーバー連結ロッド玉 (左) .....	1
3	84-5670-0	Screw .....	ネジ .....	2
4	75-3920-0	Washer .....	ワッシャ .....	1
5	75-3810-0	Washer .....	ワッシャ .....	1
6	84-6160-0	Screw .....	ネジ .....	2
7	84-7180-0	Screw .....	ネジ .....	1
8	84-7660-0	Screw .....	ネジ .....	1
9	84-7670-0	Screw .....	ネジ .....	1
10	19-3030-0	Looper rocker C .....	ルーバー元台 C .....	1
11	86-5020-0	Nut .....	ナット .....	1
12	19-3260-0	Looper holder .....	ルーバー台 .....	1
13	71-9010-0	Looper rocker tapered pin .....	ルーバー台テーバーピン .....	1
14	75-4520-0	Washer .....	ワッシャ .....	1
15	81-4010-1	Tapered pin bushing .....	テーバーピン押しブッシュ .....	1
16	84-3610-0	Screw .....	ネジ .....	1
17	86-5010-0	Nut .....	ナット .....	1
18	35-1990-0	Guide fork .....	ルーバー台用オイル案内板 .....	1
19	84-1610-0	Screw .....	ネジ .....	1
20	84-5210-0	Screw .....	ネジ .....	1
21	75-4530-0	Washer .....	ワッシャ .....	1



# 10. Thread eyelet and cover components (糸道機構及びカバー関係) DMM

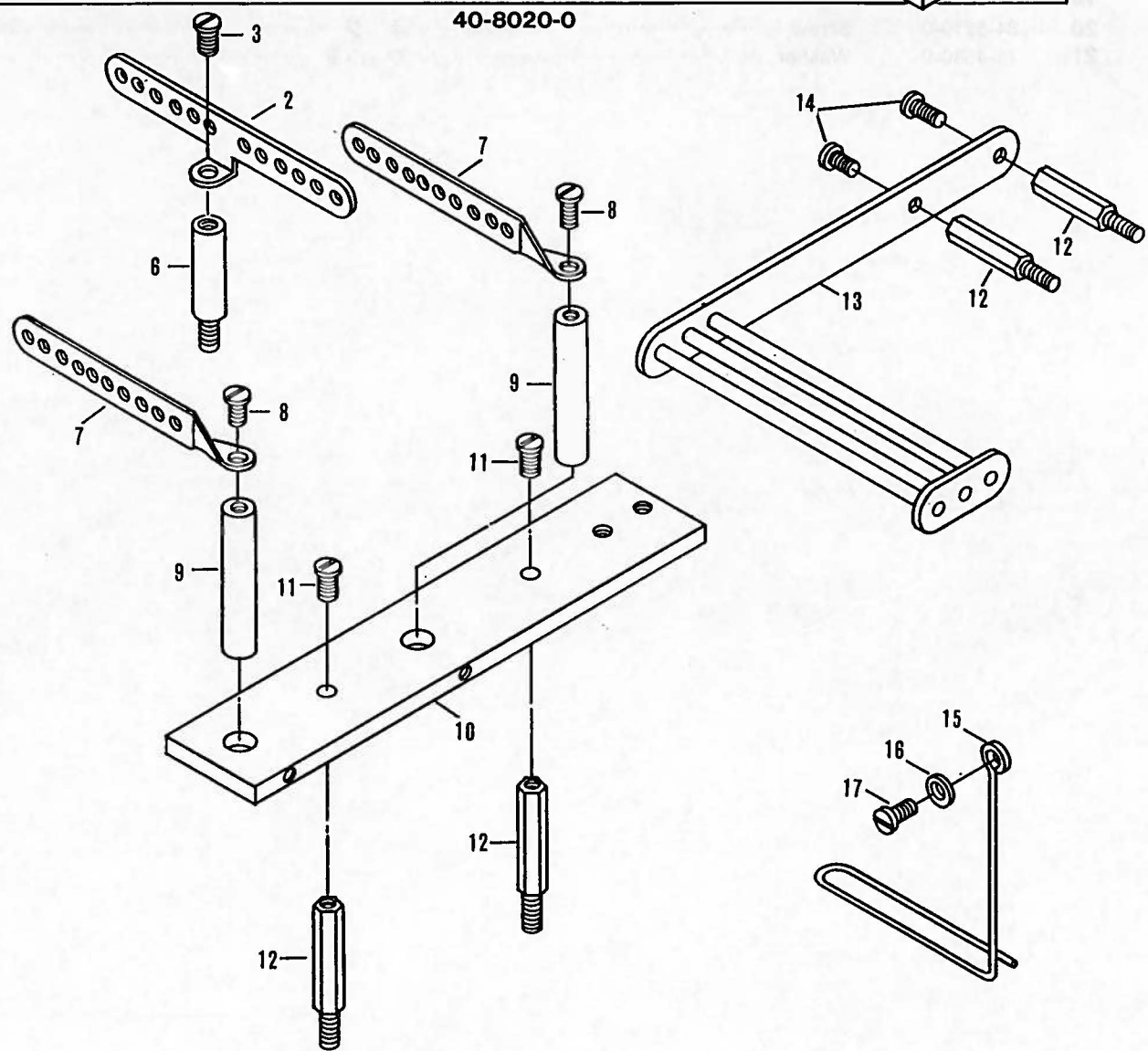
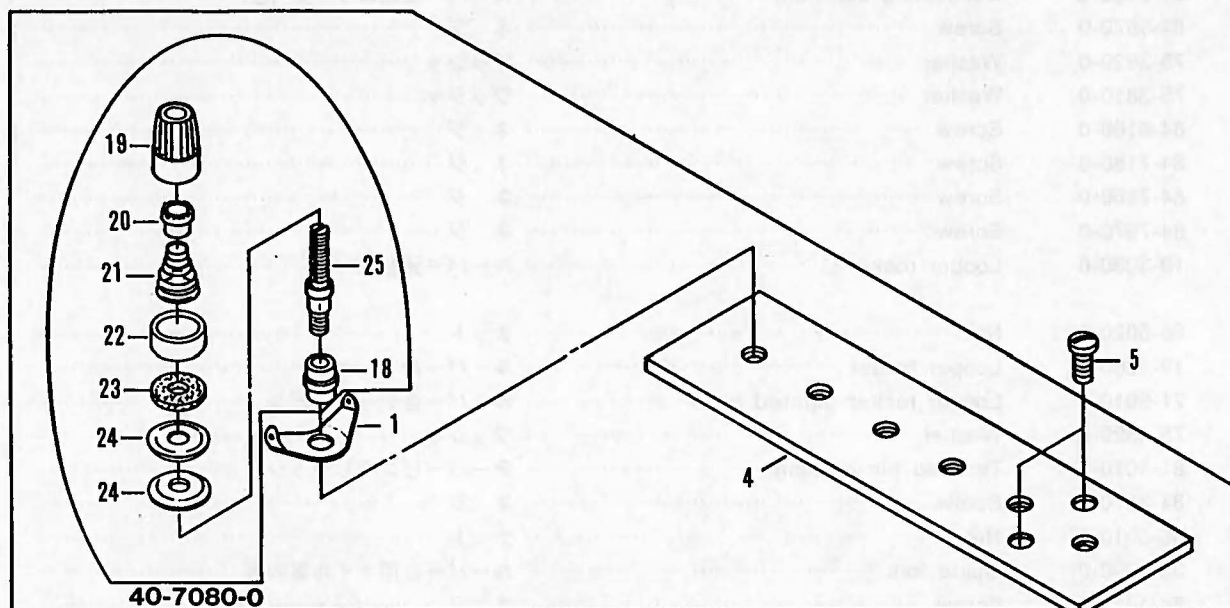

No.	Part No.	Part Name	品 名	Q, ty
1	41-1150-0	Tension post thread eyelet	糸道上	6
2	45-3440-0	Thread eyelet	12本針用飾り糸捌き	1
3	84-3740-0	Screw	ネジ	1
4	04-0100-0	Tension disc plate	飾り用チャンボン台	1
5	84-7630-0	Screw	ネジ	2
6	04-0090-0	Screw	ネジ	1
7	45-3420-0	Thread eyelet	12本針用飾り案内糸道	2
8	84-3740-0	Screw	ネジ	2
9	71-3700-0	Eyelet pin	糸道取付棒	2
10	04-0110-0	Bracket	飾り下捌き土台	1
11	84-5660-0	Screw	ネジ	2
12	26-7090-0	Screw	ネジ	4
13	45-3430-0	Thread guide	飾り糸ガイド	1
14	84-5660-0	Screw	ネジ	2
15	04-0070-0	Thread eyelet	飾り糸道	1
16	75-4550-0	Washer	ワッシャ	1
17	84-5640-0	Screw	ネジ	1
18	41-1720-0	Tension post	調子棒中	6
19	41-1010-0	Adjusting nut	チャンボン皿小ケース	6
20	41-1050-0	Adjusting ratchet	チャンボン皿	6
21	41-7020-0	Spring (weak)	チャンボン調子バネ弱	6
22	41-1070-0	Disc cover	チャンボン皿大ケース	6
23	23-3240-0	Felt	取付フェルト	6
24	41-1110-0	Disc	チャンボン皿	12
25	41-1310-0	Tension post collar A	調子棒カラー A	6





# 11. Spreader mechanism (飾り機構) DMM2202, 2203

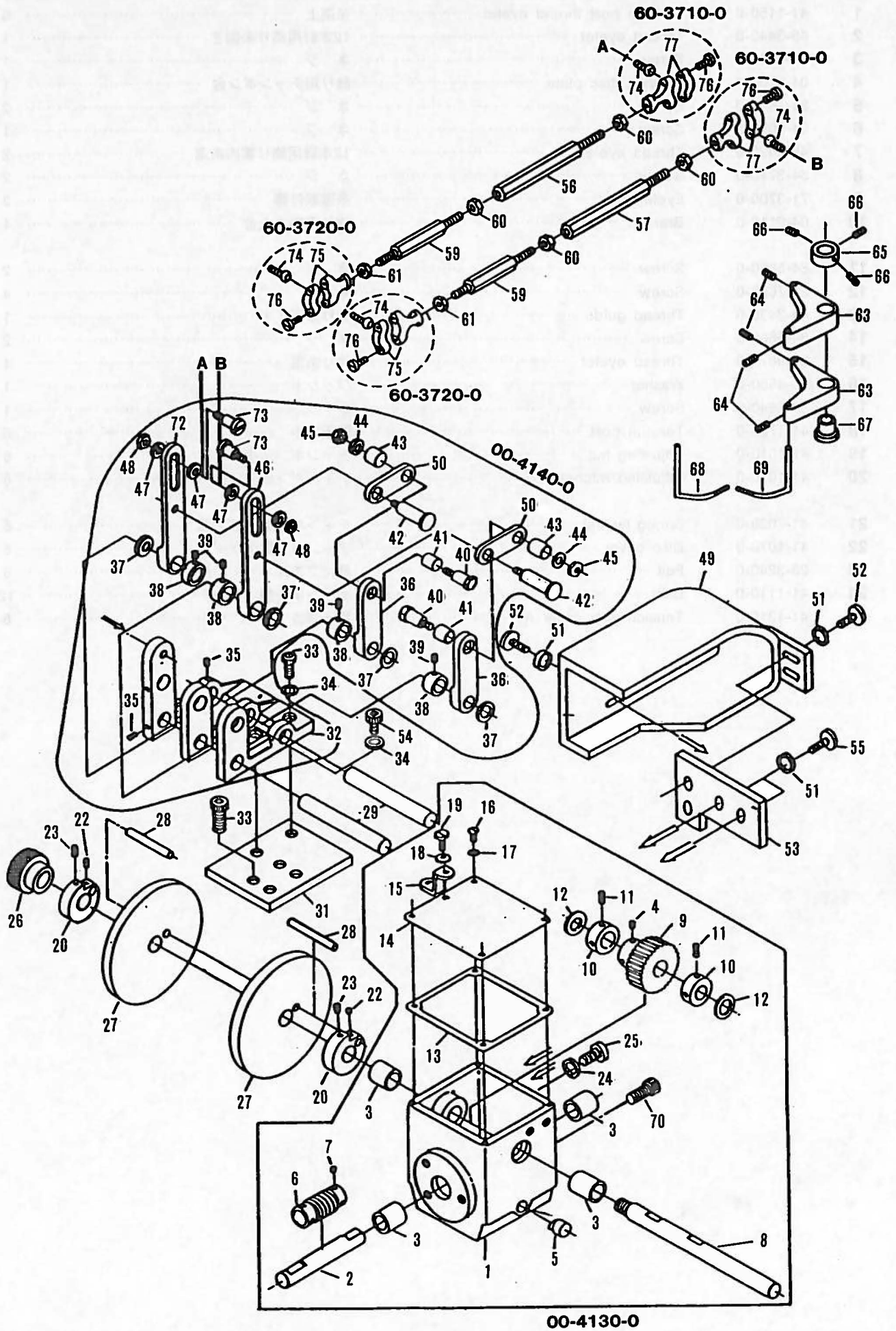



No.	Part No.	Part Name	品名	Q, ty
1	69-3200-0	Gear housing	ギヤハウジング	1
2	71-7060-0	Joint shaft	ジョイントシャフト	1
3	81-6900-0	Bushing	ブッシュ	4
4	85-1130-0	Screw	ネジ	2
5	39-2140-0	Oil gage	オイルゲージ	1
6	04-4120-0	Worm	ウォーム	1
7	85-1130-0	Screw	ネジ	4
8	71-9420-0	Cam drive shaft	12本針カムシャフト	1
9	04-4130-0	Worm Wheel	ホイール	1
10	75-1120-1	Collar	カラー	2
11	84-5630-0	Screw	ネジ	4
12	75-3320-0	Washer	ワッシャ	2
13	23-4120-0	Gasket	パッキン	1
14	21-4120-0	Gear housing cover	ギヤハウジングカバー	1
15	77-4120-0	Chain guide	チェンガイド	1
16	84-5660-0	Screw	ネジ	4
17	75-4550-0	Washer	ワッシャ	4
18	75-4550-0	Washer	ワッシャ	1
19	84-5630-0	Screw	ネジ	1
20	75-1820-0	Cam collar A	カラー	2
22	84-5120-0	Screw	ネジ	2
23	84-7180-0	Screw	ネジ	4
24	75-4700-0	Washer	ワッシャ	3
25	85-5220-0	Screw	ネジ	3
26	88-4620-0	Cam fixing nut	ナット	1
27	04-4570-0	Cam 7	カム7	2
	04-4580-0	Cam 8	カム8	2
	04-4590-0	Cam 9	カム9	2
28	04-0080-0	Cam collar pin	カムカラーピン	2
29	71-5290-0	Cam lever shaft	カムレバーシャフト	2
31	04-0010-0	Plate	カムホルダーベース	1
32	04-3420-0	Flame	飾り糸振りレバーベース	1
33	85-6270-0	Screw	ネジ	3
34	75-4520-0	Washer	ワッシャ	5
35	84-5210-0	Screw	ネジ	2
36	67-4310-0	Lever	カムリンクレバー	2
37	75-4330-0	Washer	ワッシャ	4
38	75-1520-1	Collar	カラー	4
39	84-5110-0	Screw	ネジ	8
40	84-6070-0	Screw	ネジ	2
41	75-2600-0	Roller	ローラー	2
42	84-6050-0	Screw	ネジ	2
43	75-2570-0	Link roller	リンクローラー	2
44	75-3890-0	Washer	ワッシャ	2
45	86-3110-0	Nut	ナット	2
46	67-4340-0	Lever	飾り糸振りレバー	1
47	75-4520-0	Washer	ワッシャ	4
48	86-3110-0	Nut	ナット	2
49	21-4880-0	Cam cover	カムカバー	1
50	66-4330-0	Link	カム連結リンク	2
51	75-4550-0	Washer	ワッシャ	5
52	84-5790-0	Screw	ネジ	3
53	21-4900-0	Cam over arm C	カムカバー取付金具C	1
54	85-6280-0	Screw	ネジ	2
55	84-5660-0	Screw	ネジ	2
56	04-0030-0	Studs bolt	タイボルト	1
57	04-0040-0	Studs bolt	タイボルト	1
59	65-4340-1	Connecting screw	ルーバー連結棒C	2
60	86-4110-0	Nut R	ナット右	4
61	86-4120-0	Nut L	ナット左	2
63	67-2030-0	Spreader lever	左スプレッターレバー	2
64	84-5210-0	Screw	ネジ	4
65	75-1890-0	Collar	カラー	1
66	84-5210-0	Screw	ネジ	3
67	04-0020-0	Bearing sleeve	ベアリングインナーレース	1
68	04-0050-0	Spreader (L)	スプレッター左	1
69	04-0060-0	Spreader (R)	スプレッター右	1
70	87-1710-0	Screw	ギヤハウジング止めネジ	3
72	67-4350-0	Connecting lever	飾り糸振りレバーB 1/4"	1
73	84-6060-0	Screw	飾り糸振りリンクネジ	2
74	61-8230-U	Looper connecting ball joint (left)	連結ロッド玉(左)	2
75	63-8120-1	Looper connecting rod (left)	連結ロッド(左)	2
76	84-5670-0	Screw	ネジ	2
77	63-8110-1	Looper connecting rod (right)	連結ロッド(右)	2



## 12. Gauge parts (ゲージ関係)

### V7002D/UTC (5/32", 1/8")

Needle holder (針株)  
(2 needles)

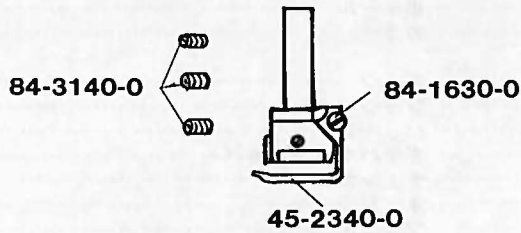

	$\frac{m}{in}$	Part No.
5/32"	3.97	12-8120-1
1/8"	3.17	12-8110-1

Needle plate (針板)  
(2 needle)

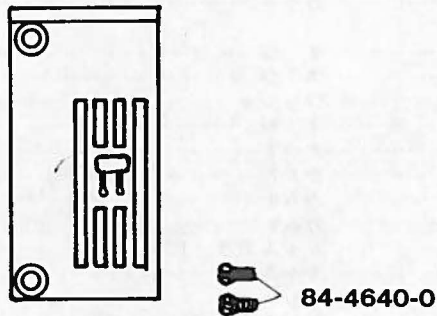

	$\frac{m}{m}$	Part No.
5/32"	3.97	14-7340-0
1/8"	3.17	14-7240-0

Presser foot (押え)  
(2 needle)

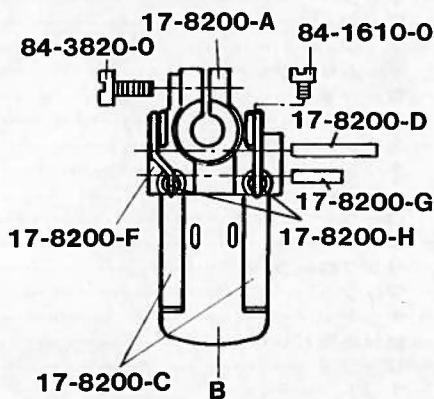

	$\frac{m}{m}$	Part No.
5/32"	3.97	17-7340-1
1/8"	3.17	17-7240-1

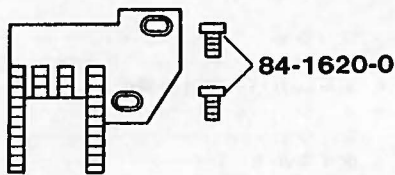

Feed dog (rear)  
(後送り歯)  
15-7420-0

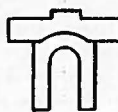



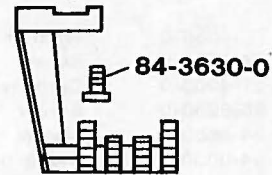

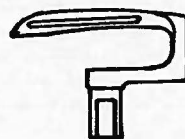

Rear feed dog holder  
(後送り取付台)  
51-7720-0

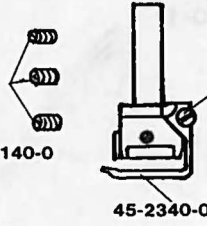
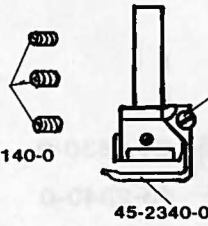

Feed dog (front)  
(前送り歯)  
15-7320-0

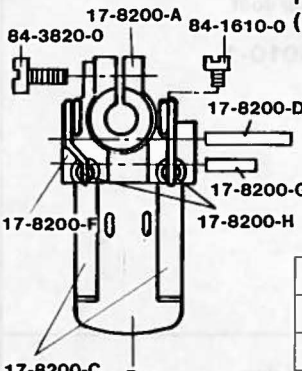
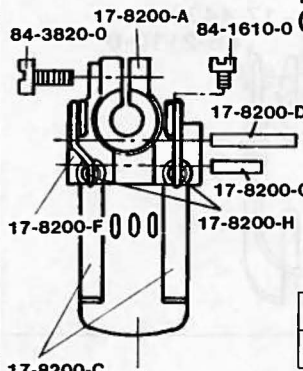
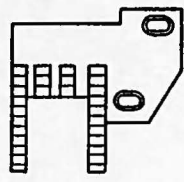

Looper (ルーパー)  
19-8010-0

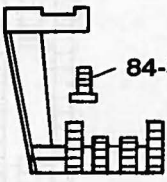
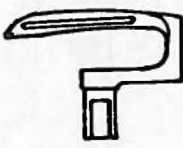
V7002D/UTC (3/16" ~ 1/4")	V7003D/UTC (7/32", 1/4")															
<p><b>Needle holder (針株) (2 needles)</b></p>  <p>84-3140-0      84-1630-0      45-2340-0</p> <table border="1" data-bbox="486 448 758 571"> <tr> <td>3/16"</td> <td>4.76</td> <td>12-8130-</td> </tr> <tr> <td>7/32"</td> <td>5.56</td> <td>12-8140-1</td> </tr> <tr> <td>1/4"</td> <td>6.35</td> <td>12-8150-1</td> </tr> </table>	3/16"	4.76	12-8130-	7/32"	5.56	12-8140-1	1/4"	6.35	12-8150-1	<p><b>Needle holder (針株) (3 needles)</b></p>  <p>84-3140-0      84-1630-0      45-2340-0</p> <table border="1" data-bbox="1093 481 1364 560"> <tr> <td>7/32"</td> <td>5.56</td> <td>12-8010-1</td> </tr> <tr> <td>1/4"</td> <td>6.35</td> <td>12-8020-1</td> </tr> </table>	7/32"	5.56	12-8010-1	1/4"	6.35	12-8020-1
3/16"	4.76	12-8130-														
7/32"	5.56	12-8140-1														
1/4"	6.35	12-8150-1														
7/32"	5.56	12-8010-1														
1/4"	6.35	12-8020-1														
<p><b>Needle plate (針板) (2 needles)</b></p>  <table border="1" data-bbox="486 705 758 817"> <tr> <td>3/16"</td> <td>4.76</td> <td>14-7440-0</td> </tr> <tr> <td>7/32"</td> <td>5.56</td> <td>14-7540-0</td> </tr> <tr> <td>1/4"</td> <td>6.35</td> <td>14-7640-0</td> </tr> </table>  <p>84-4640-0</p>	3/16"	4.76	14-7440-0	7/32"	5.56	14-7540-0	1/4"	6.35	14-7640-0	<p><b>Needle plate (針板) (3 needles)</b></p>  <table border="1" data-bbox="1093 739 1364 817"> <tr> <td>7/32"</td> <td>5.56</td> <td>14-8540-0</td> </tr> <tr> <td>1/4"</td> <td>6.35</td> <td>14-8640-0</td> </tr> </table>  <p>84-4640-0</p>	7/32"	5.56	14-8540-0	1/4"	6.35	14-8640-0
3/16"	4.76	14-7440-0														
7/32"	5.56	14-7540-0														
1/4"	6.35	14-7640-0														
7/32"	5.56	14-8540-0														
1/4"	6.35	14-8640-0														
<p><b>Presser foot (押え) (2 needles)</b></p>  <p>17-8200-A      84-3820-0      84-1610-0 17-8200-D 17-8200-G 17-8200-F      17-8200-H 17-8200-C      B</p> <table border="1" data-bbox="486 1265 758 1377"> <tr> <td>3/16"</td> <td>4.76</td> <td>17-7440-1</td> </tr> <tr> <td>7/32"</td> <td>5.56</td> <td>17-7540-1</td> </tr> <tr> <td>1/4"</td> <td>6.35</td> <td>17-7640-1</td> </tr> </table>	3/16"	4.76	17-7440-1	7/32"	5.56	17-7540-1	1/4"	6.35	17-7640-1	<p><b>Presser foot (押え) (3 needles)</b></p>  <p>17-8200-A      84-3820-0      84-1610-0 17-8200-D 17-8200-G 17-8200-F      17-8200-H 17-8200-C      B</p> <table border="1" data-bbox="1093 1299 1364 1377"> <tr> <td>7/32"</td> <td>5.56</td> <td>17-7840-1</td> </tr> <tr> <td>1/4"</td> <td>6.35</td> <td>17-7940-1</td> </tr> </table>	7/32"	5.56	17-7840-1	1/4"	6.35	17-7940-1
3/16"	4.76	17-7440-1														
7/32"	5.56	17-7540-1														
1/4"	6.35	17-7640-1														
7/32"	5.56	17-7840-1														
1/4"	6.35	17-7940-1														
 <p>84-1620-0</p> <p><b>Feed dog (rear) (後送り歯) 15-7430-0</b></p>	 <p><b>Rear feed dog holder (後送り歯取付台) 51-7720-0</b></p>	 <p>84-3630-0</p> <p><b>Feed dog (front) (前送り歯) 15-7330-0</b></p>														
 <p><b>Looper (ルーバー) 19-8010-0</b></p>																



# L5001M/UTC

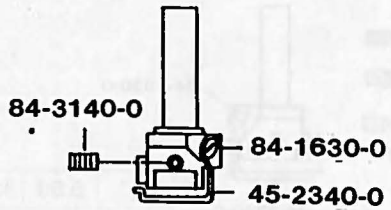

**Needle holder**  
(針株)  
**12-8010-1**

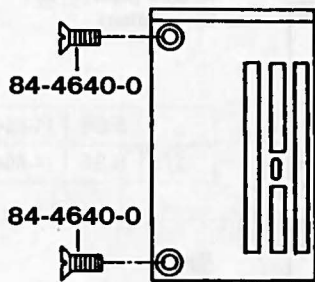

**Needle plate**  
(針板)  
**14-5010-0**

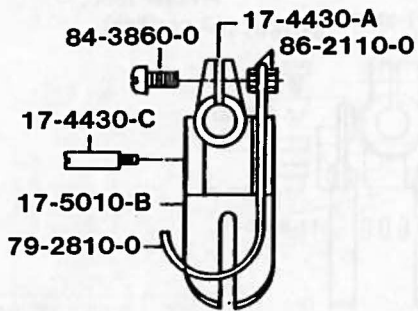

**Presser foot**  
(押え)  
**17-5010-1**

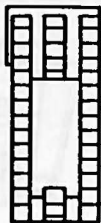

**Feed dog**  
(送り歯)  
**15-5010-0**

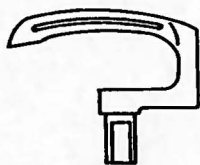

**Looper**  
(ルーパー)  
**19-5040-0**

**V7002-IS 3.5-4**

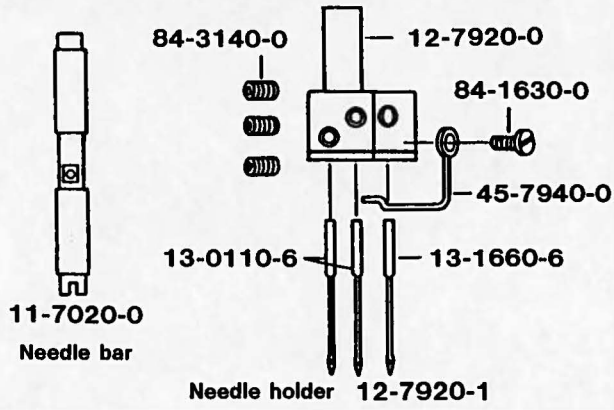

**W8003-IS (7/32"-5/32")**

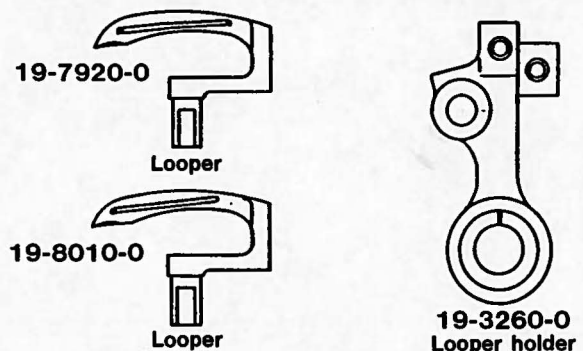
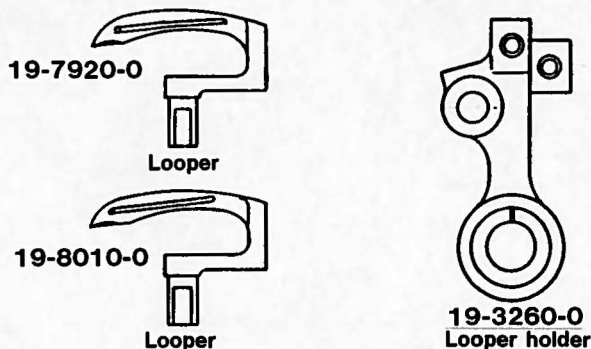
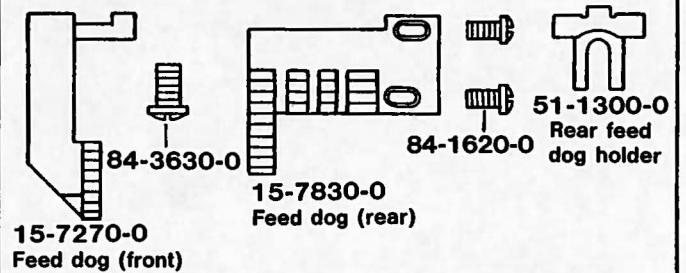
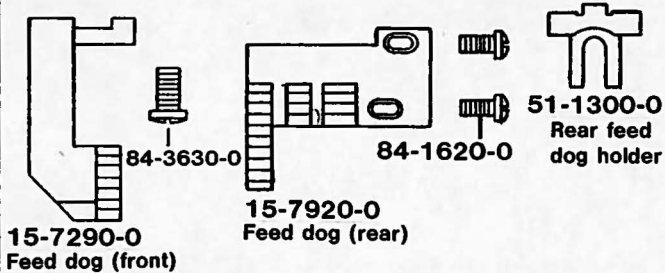
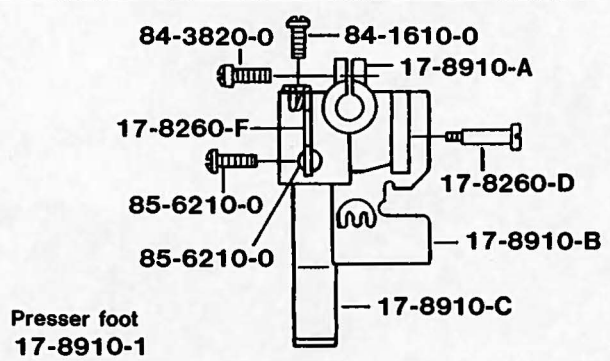
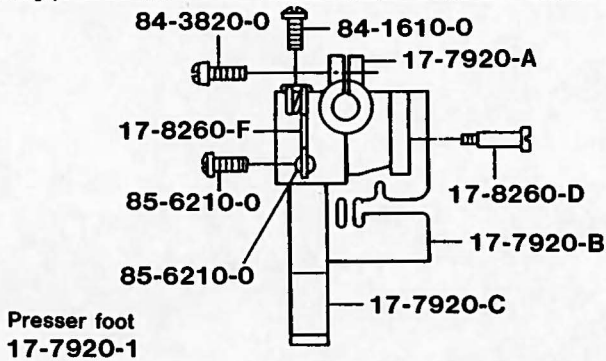
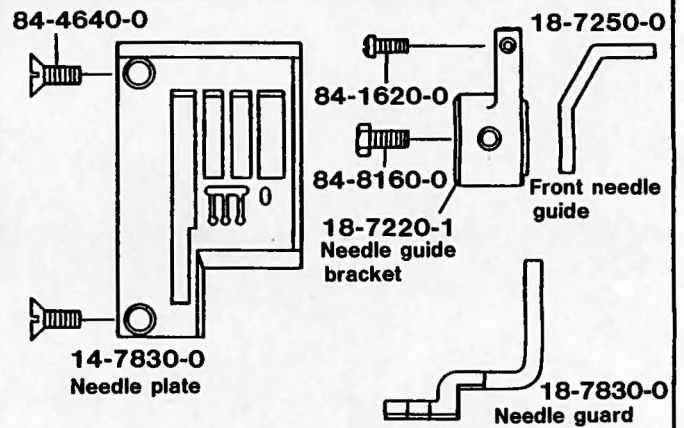
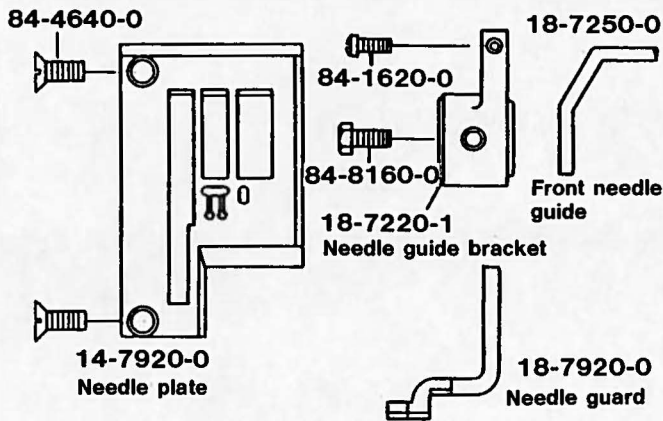
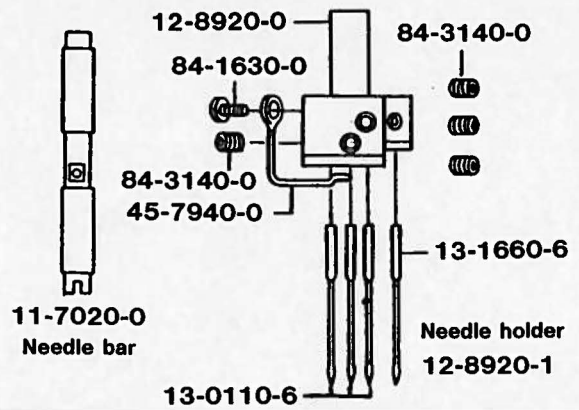



**M E M O**

W8003-18

A-2.2 81-5007V

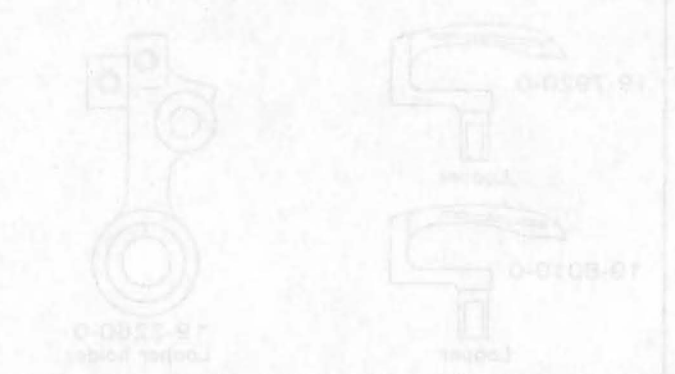
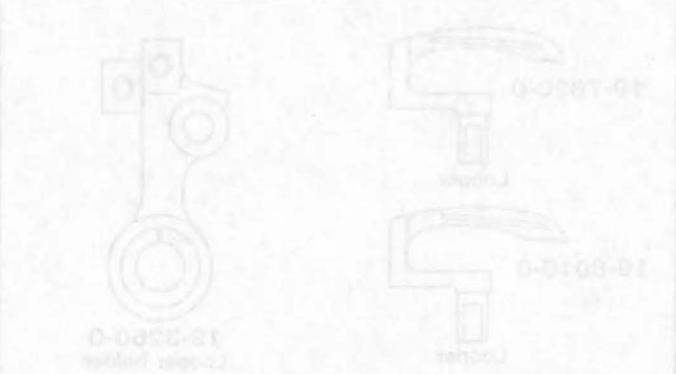
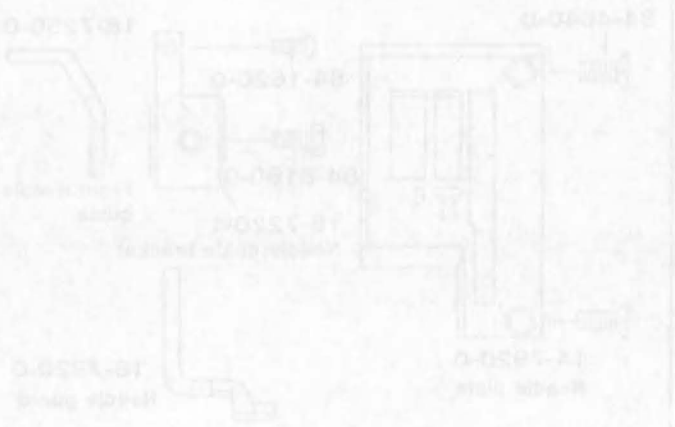
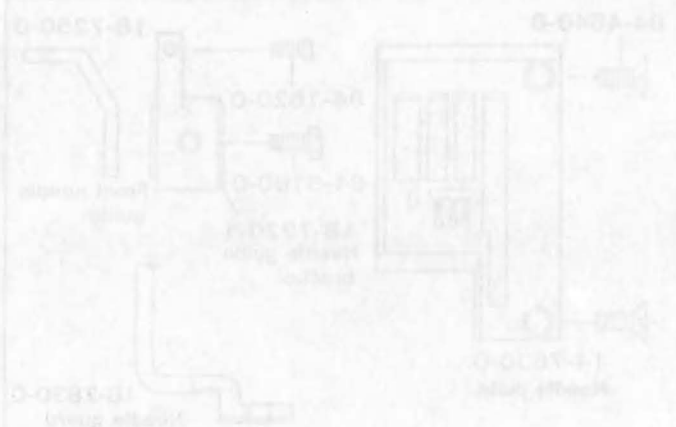
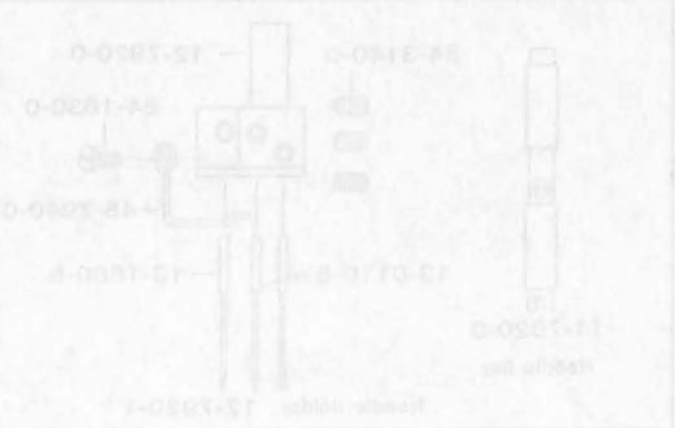
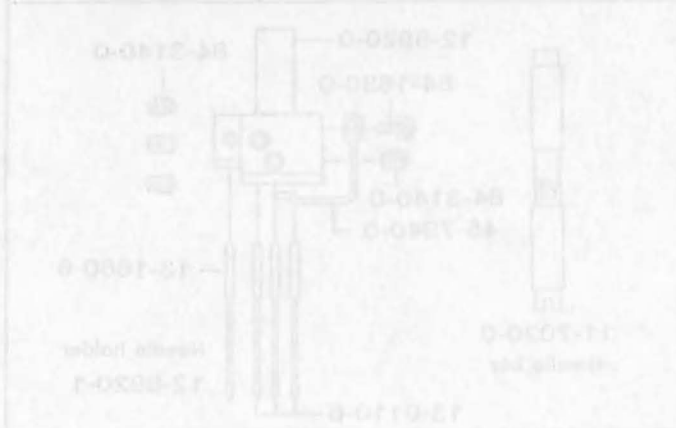

MEMO

MEMO



M E M O

O M E M

MEMO

MEMO



MEMO

MEMO

MEMO

MEMO



MEMO

MEMO





 **MORIMOTO MFG. CO., LTD.****MAIN FACTORY**

180, Suna Shijohnawate-city, Osaka 575, Japan

Tel: (0720) 77-1221 Telex: 5349134 KSPCAL-J Fax: (0720) 78-9649

**TOKYO OFFICE**

5-16-7, Kohtobashi Sumida-ku, Tokyo 130, Japan

Tel: (03) 635-5121 Fax: (03) 635-5123

**OKAYAMA OFFICE**

Village Okuda 1F, 24-19, Okuda-Honmachi Okayama-city 700, Japan

Tel: (0862) 32-9120 Fax: (0862) 22-8292

**KANSAI SPECIAL U.S.A. CORP.**

640 Gotham Parkway Carlstadt N.J. 07072 U.S.A.

Tel: (201) 460-0350 Telex: 219449 (KSPCUR) Fax: (201) 460-1633

**MORIMOTO MFG. (H.K.) LTD.**

203-207 G/F., Lai Chi Kok Road, Sham Shui Po, Kowloon, Hong Kong

Tel: 3-918357-9 Telex: 31167 MORHK HX Fax: 3-7891707

**MORIMOTO MFG. (H.K.) LTD. SINGAPORE REP. OFFICE**

66 East Coast Road, #04-04 Grth Building Singapore 1542

Tel: 3457576 Telex: RS25138 A/B: MMSPL Fax: 3449603

**KANSAI SPECIAL MI EUROPE G.M.B.H.**

Wahler Strasse 37 4000 Düsseldorf, 30 W. GERMANY

Tel: 0211-658020 Telex: 8586555 KSWGD Fax: 0211-6581529